

Portal-Masked Environment Map Sampling

Benedikt Bitterli ^{1,2}

Jan Novák ²

Wojciech Jarosz ²

¹ Walt Disney Animation Studios



² Disney Research Zurich



Motivation



Motivation



Environment Map Sampling

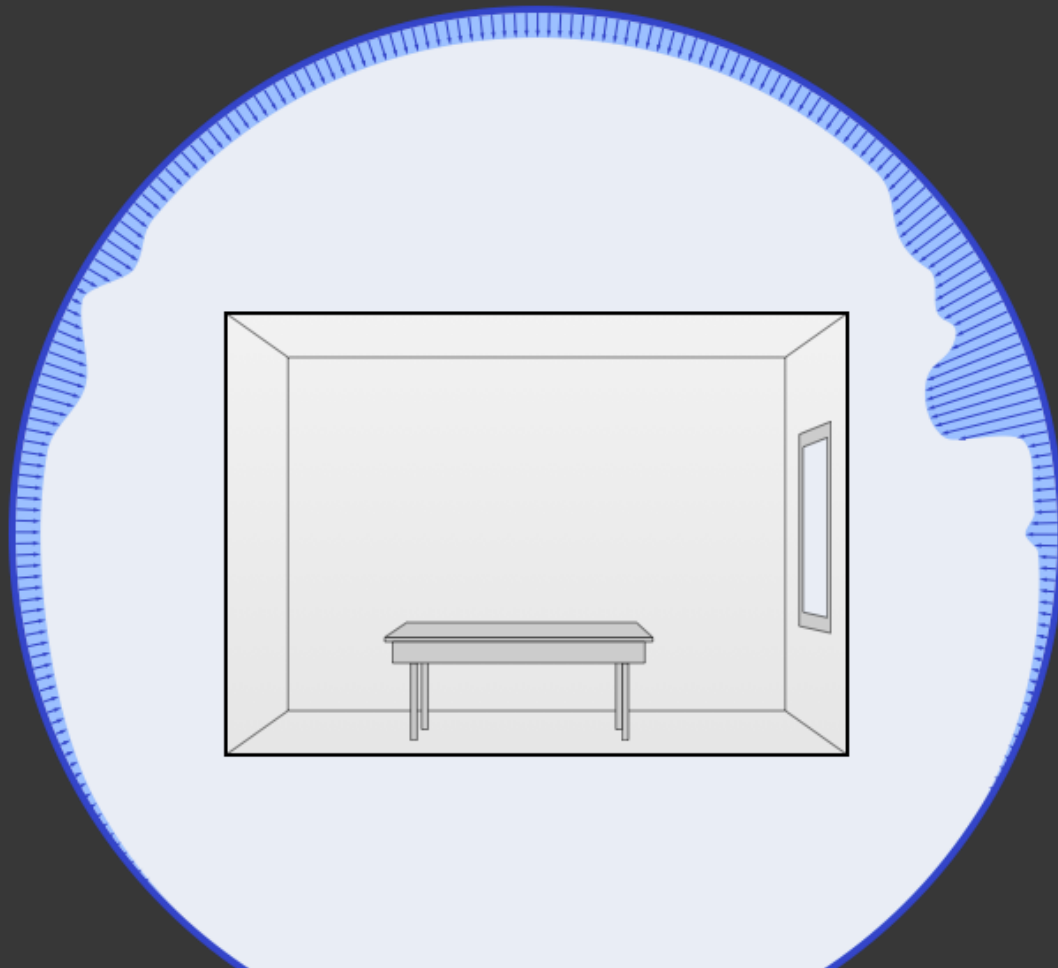

Environment Map Sampling

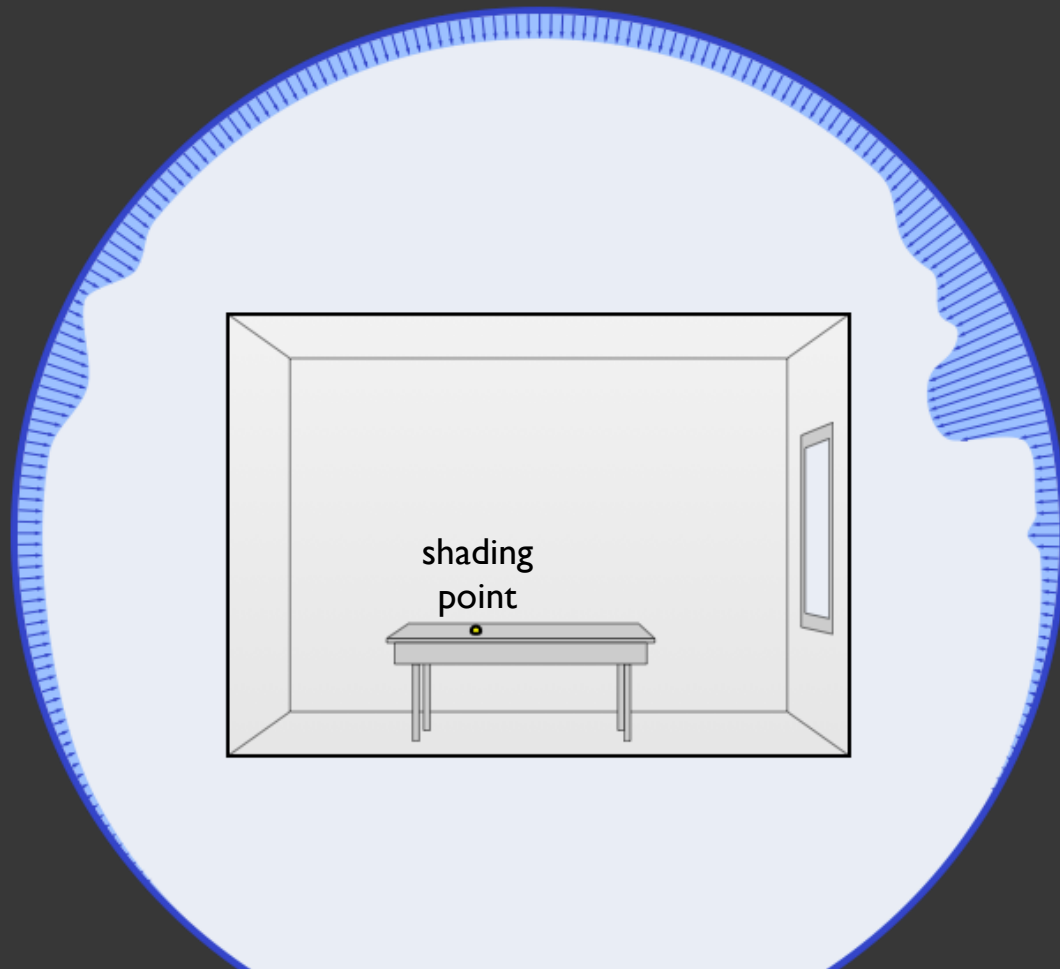

Environment Map Sampling

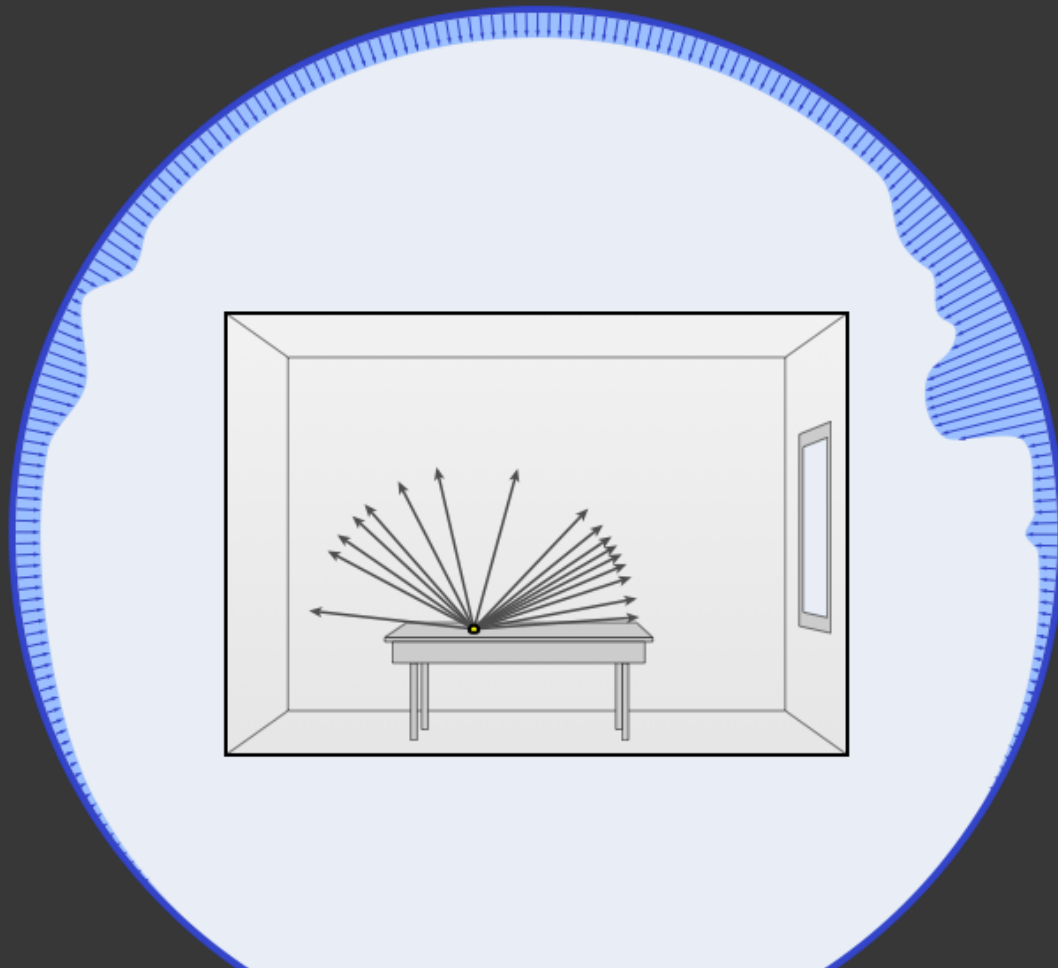

Environment Map Sampling

[Kollig and Keller]

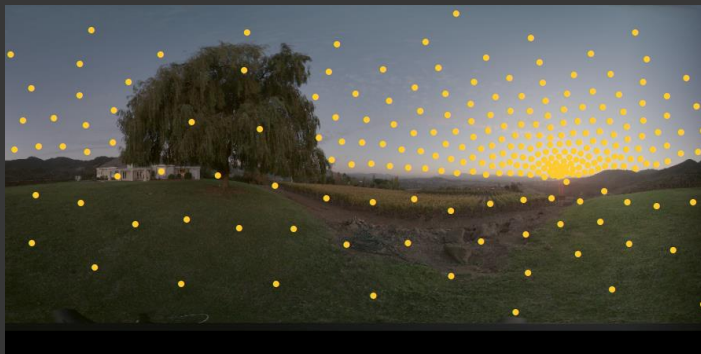

[Ostromoukhov et al.]

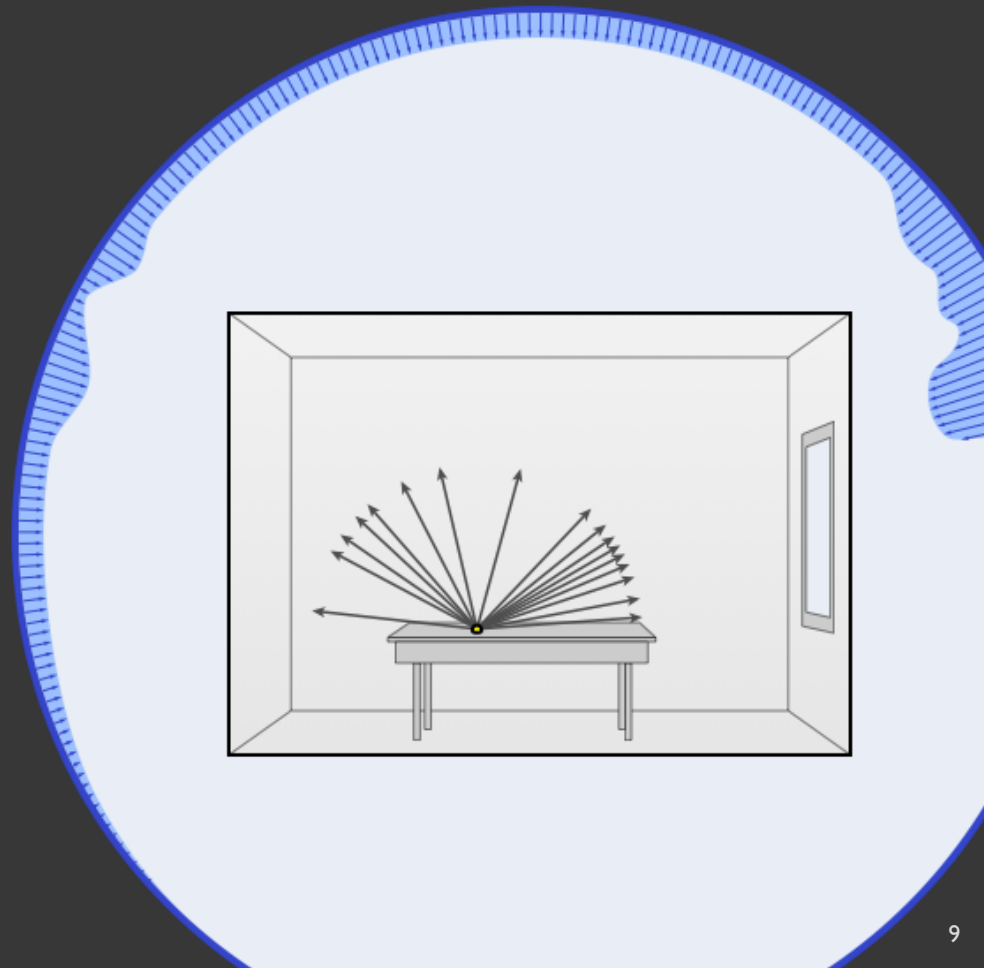

Environment Map Sampling

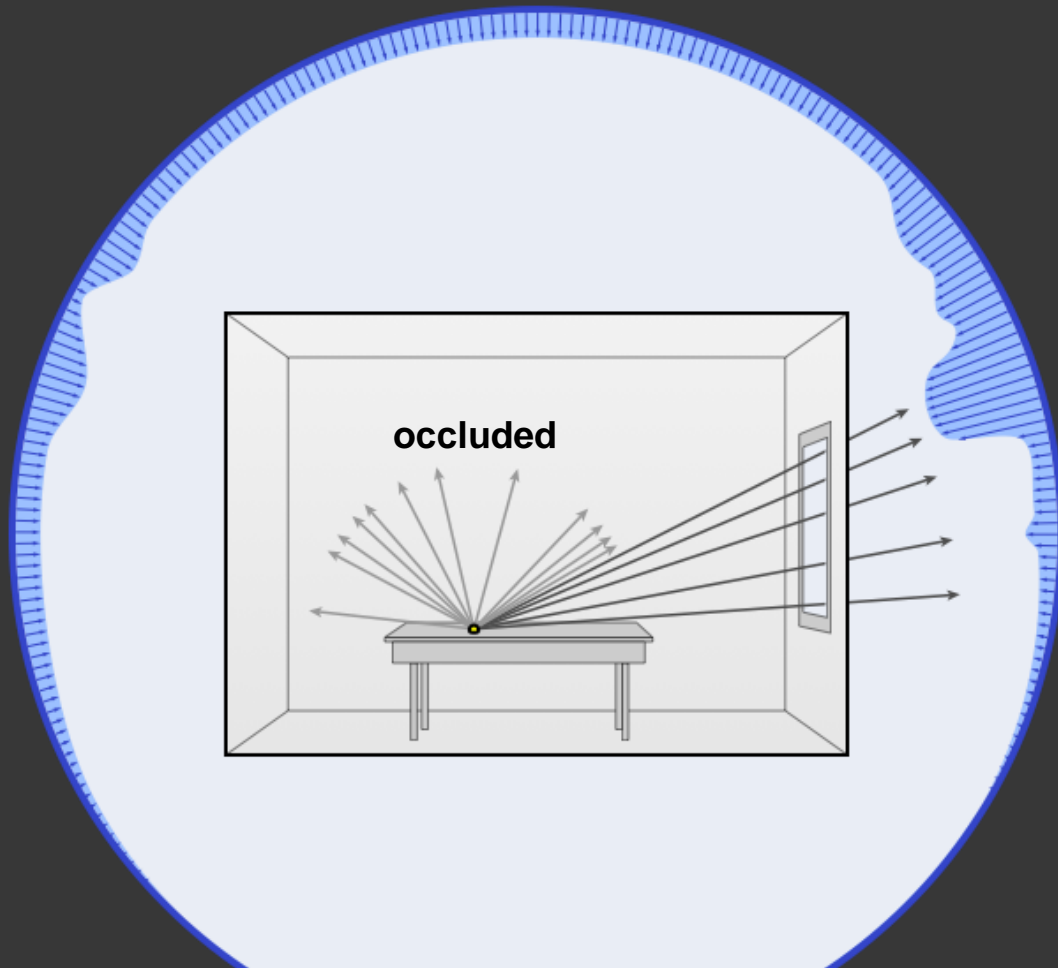

Problem Statement

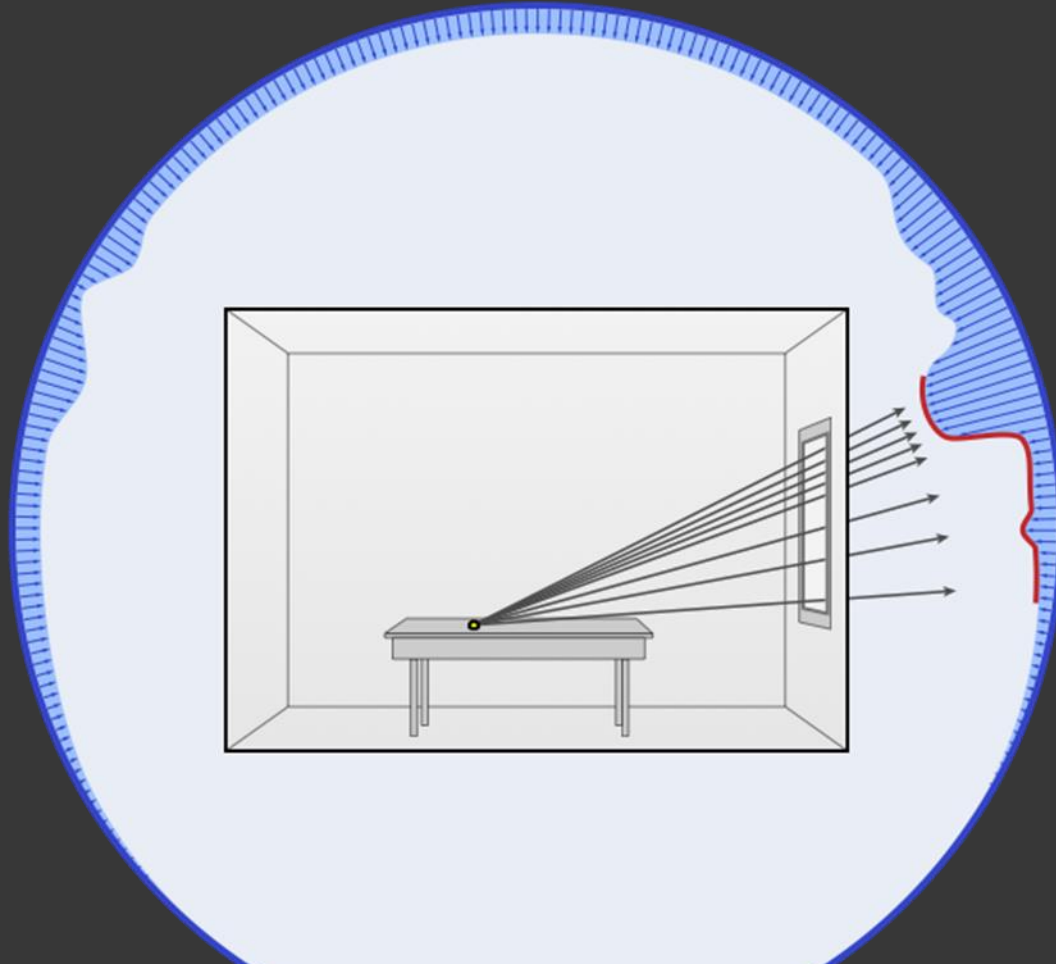

Visibility Caching

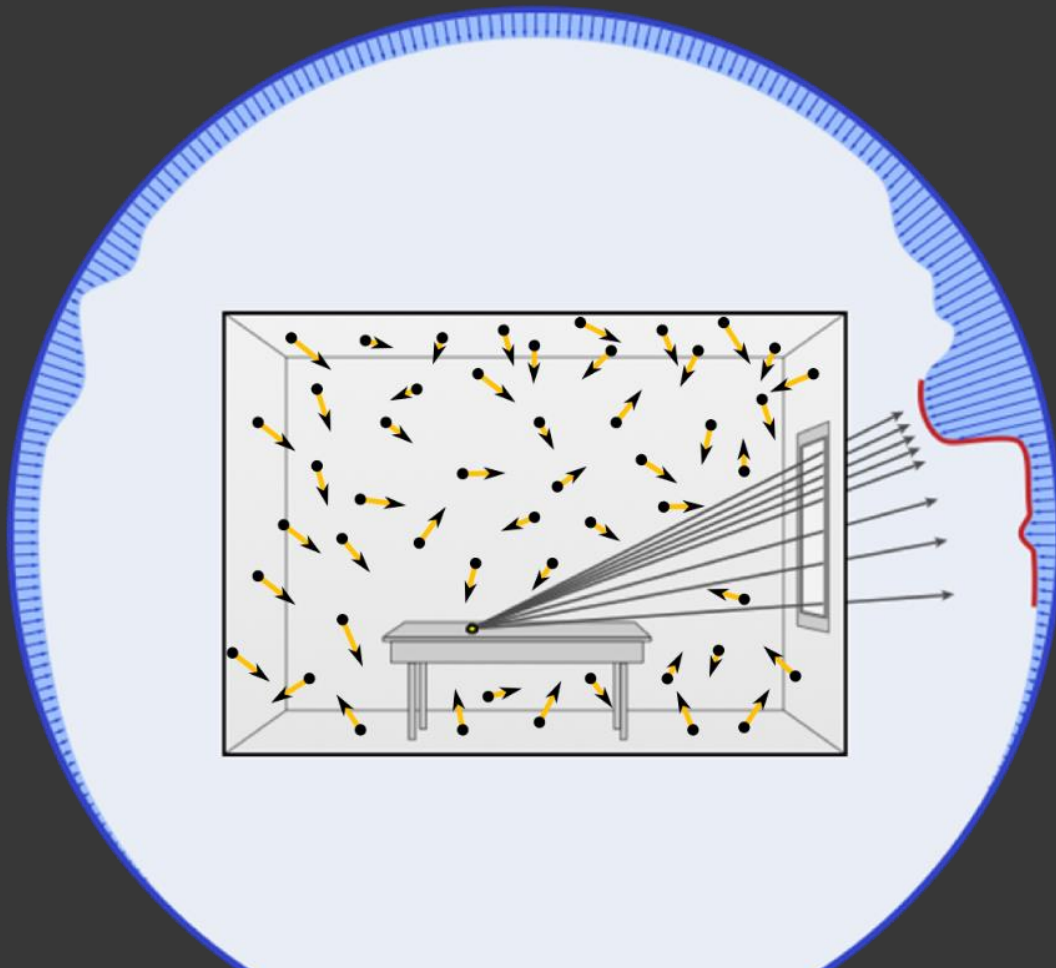

Visibility Caching

[Jensen '95]



[Georgiev et al.]

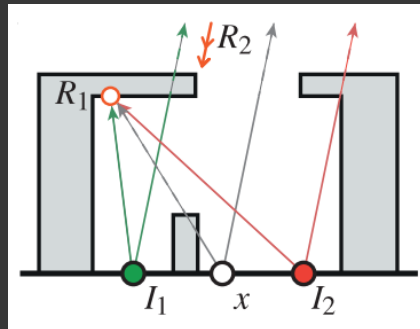

[Vorba et al.]

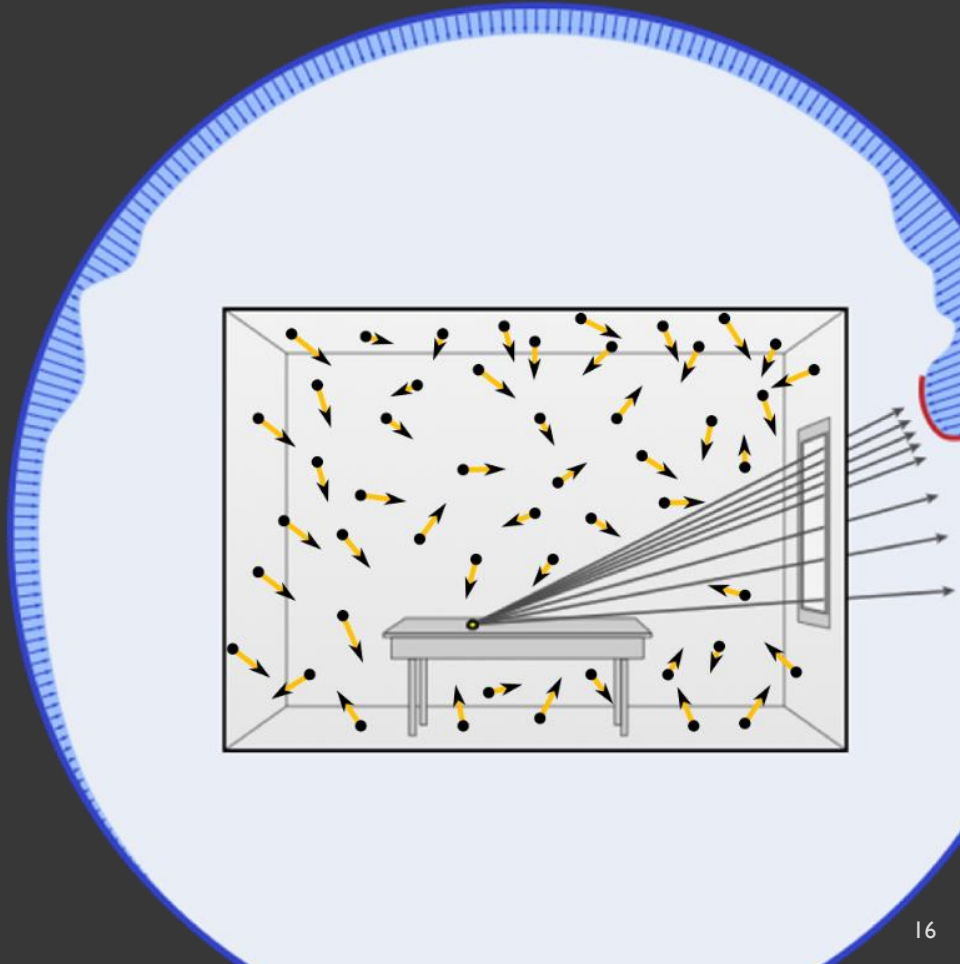
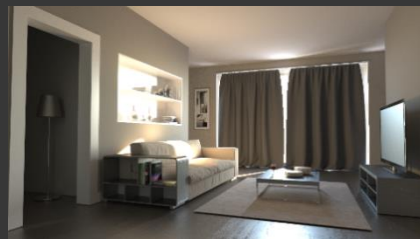

Portal Sampling

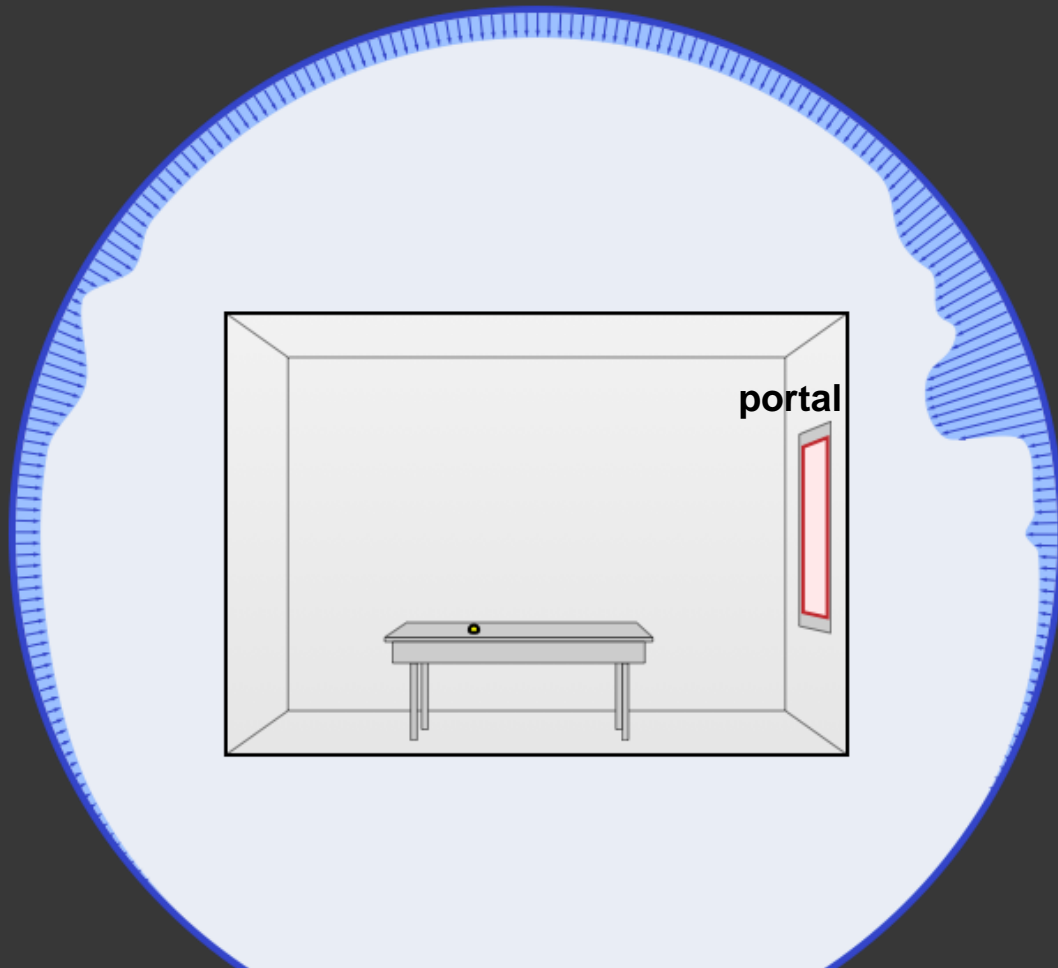

Portal Sampling

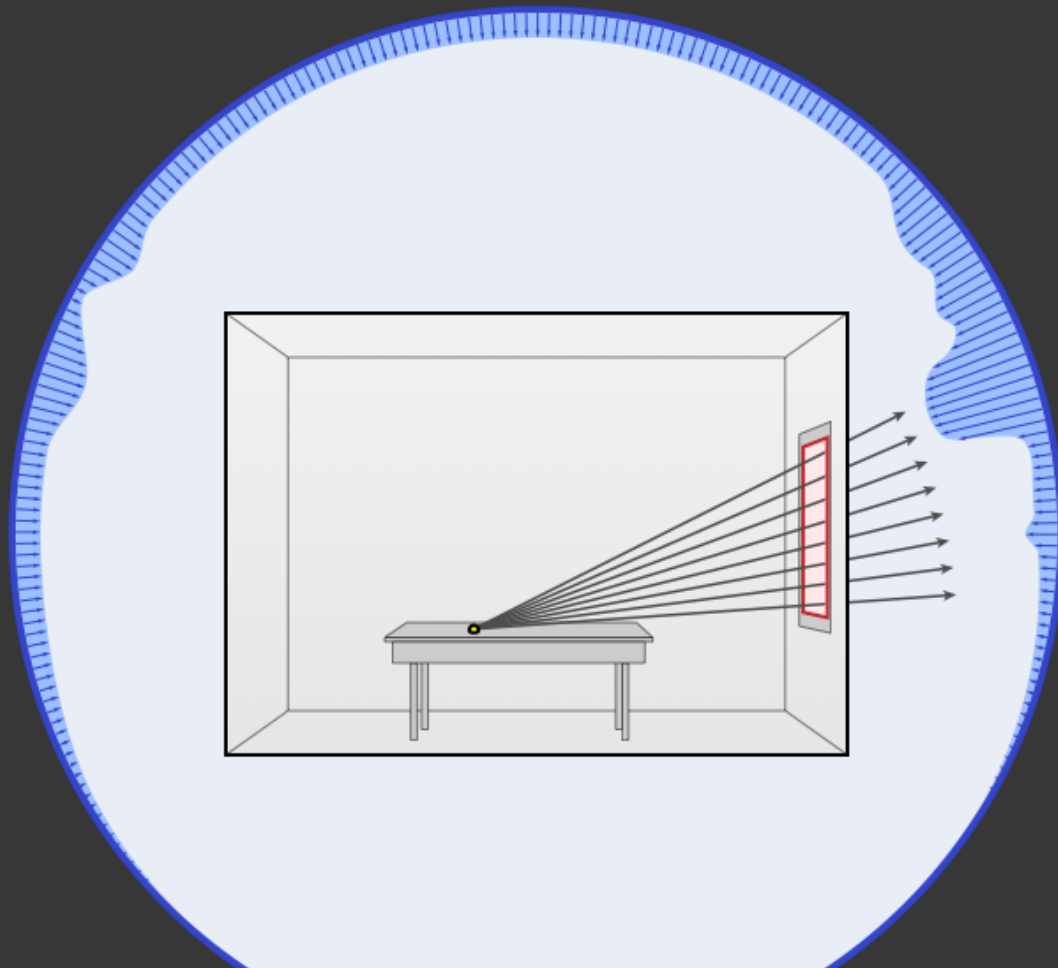

Portal Sampling

[Arvo '95]

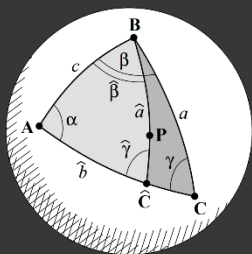

[Ureña et al.]

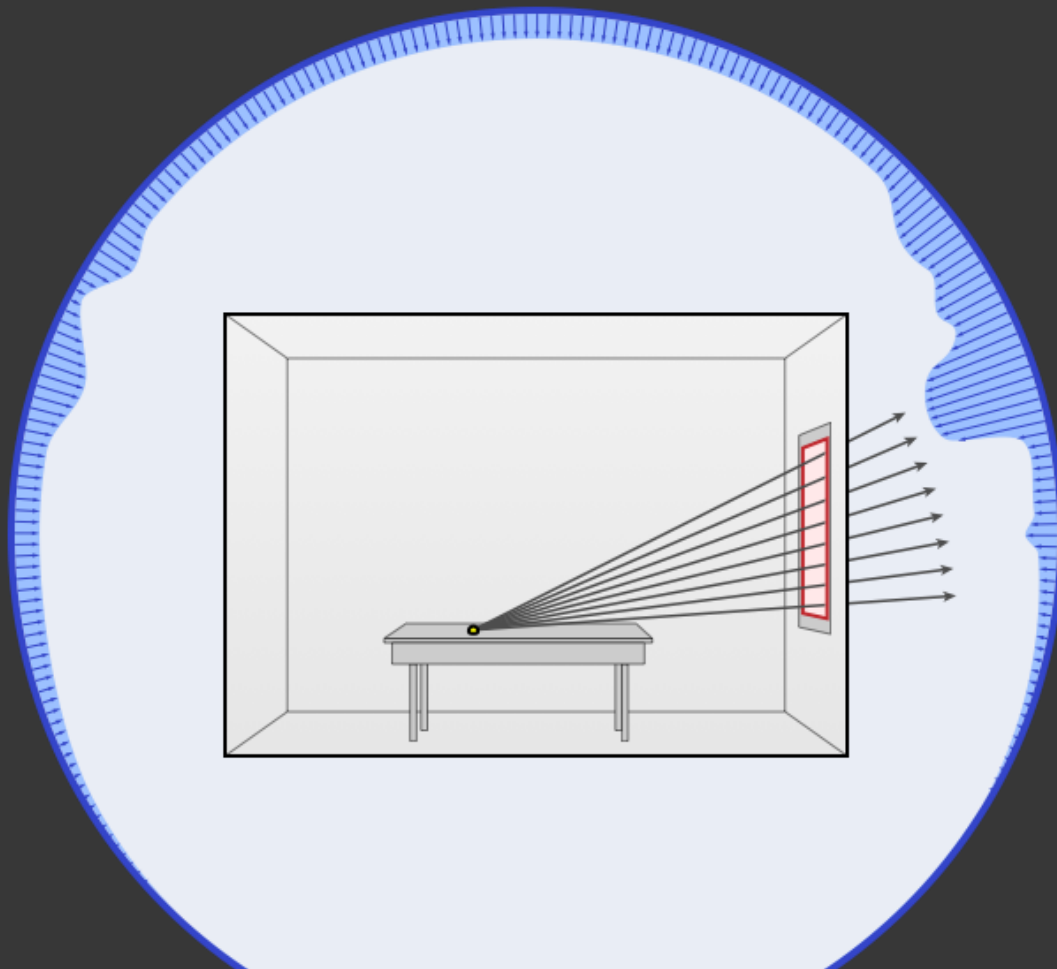
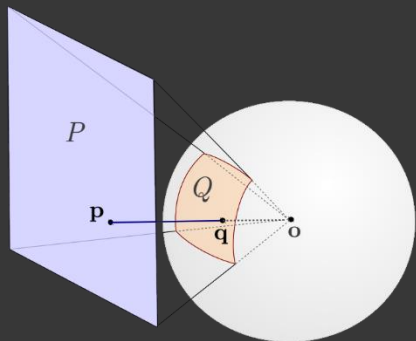

Portal Sampling

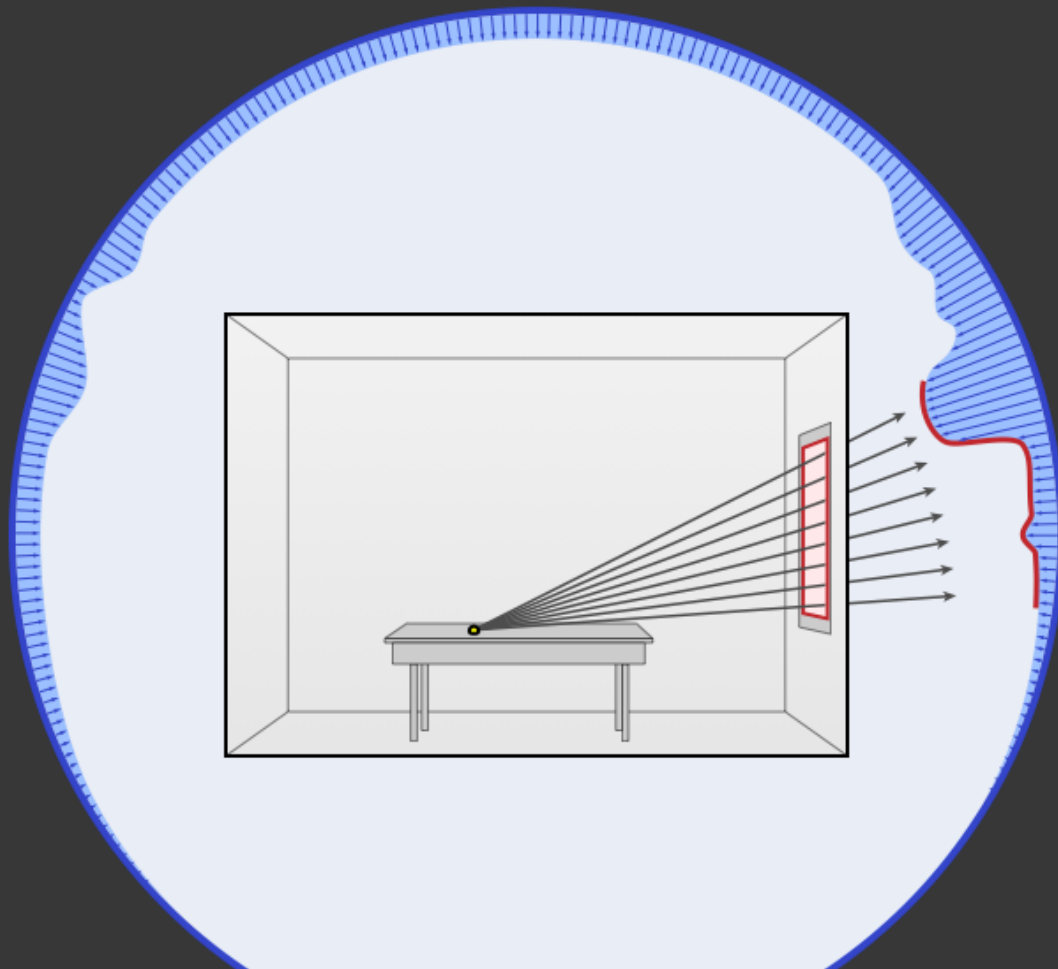

Ours

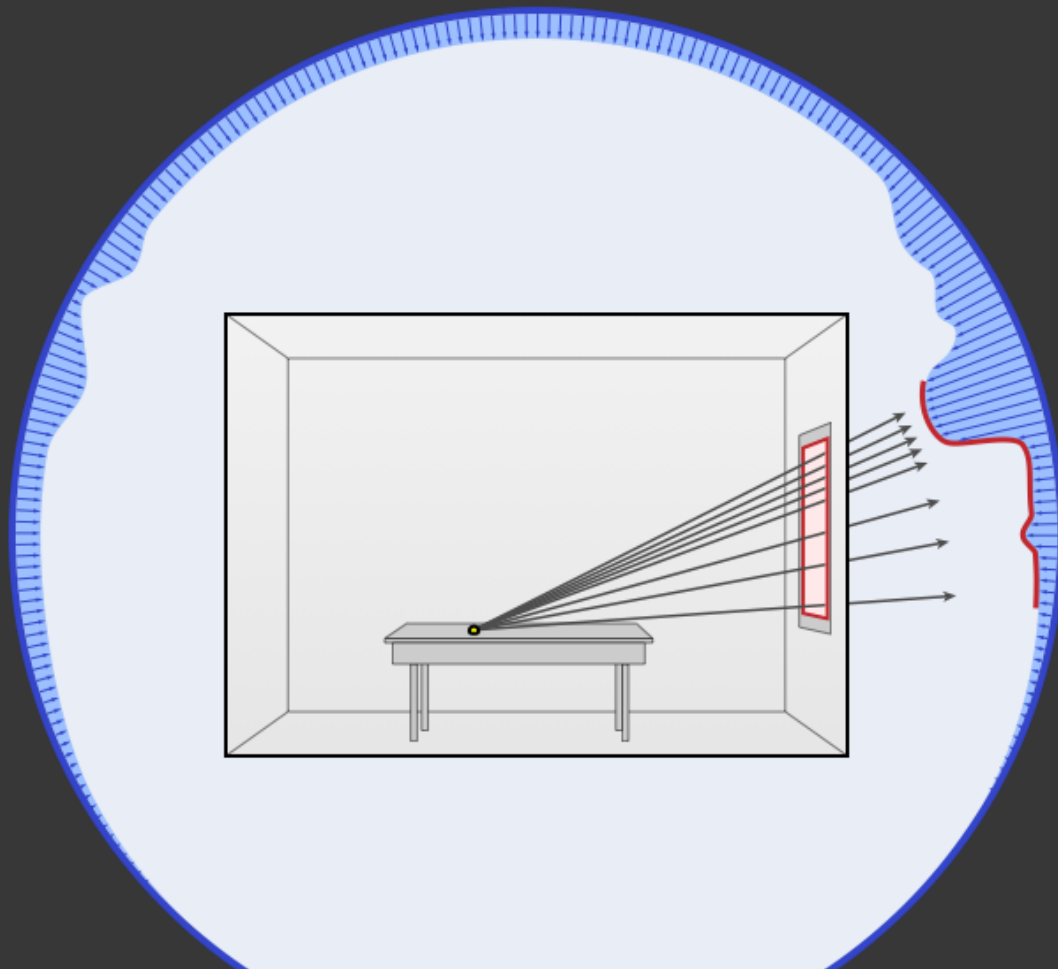

Environment Map Sampling



Environment Map Sampling

marginal distribution

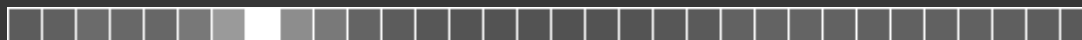

conditional distributions

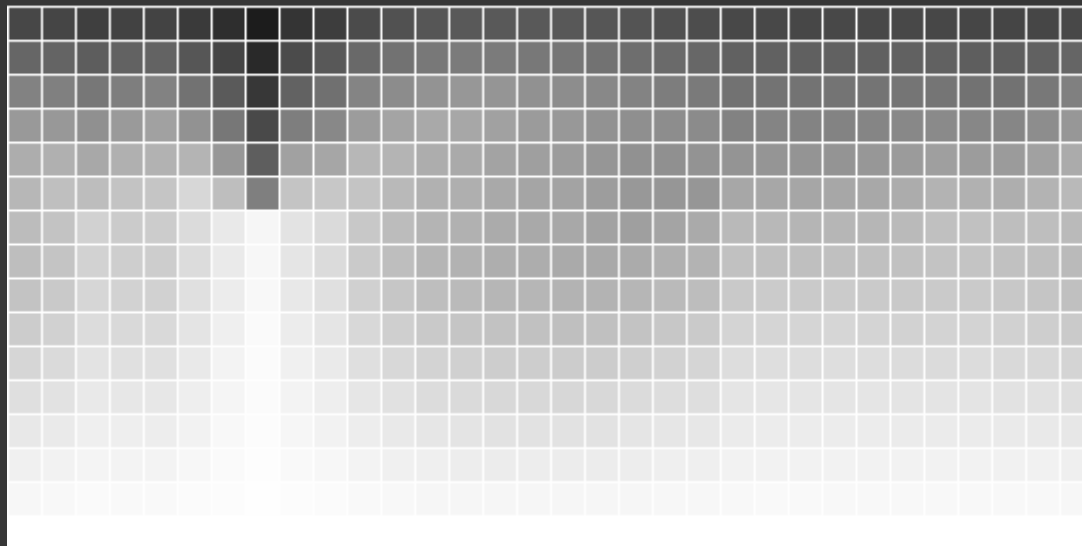

Visible Region

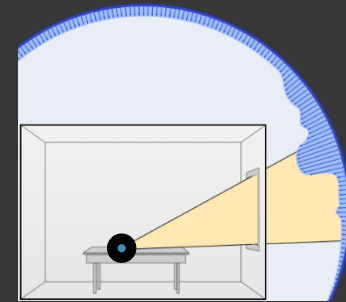

Visible Region

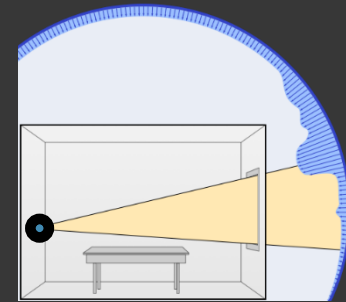

Visible Region

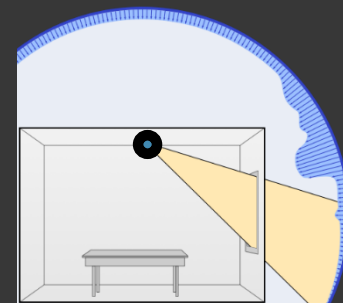

Portal-Masked Environment Map Sampling

Challenges:

- 1) Visible regions have complex shapes
Marginal/conditional decomposition difficult

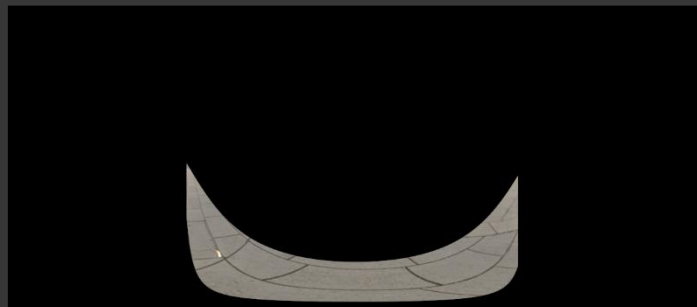

Portal-Masked Environment Map Sampling

Challenges:

- 1) Visible regions have complex shapes
Marginal/conditional decomposition difficult
- 2) Visible regions different for each shading point
Marginal/conditional cannot be precomputed



Portal-Masked Environment Map Sampling

Challenges:

- 1) Visible regions have complex shapes
Marginal/conditional decomposition difficult
- 2) Visible regions different for each shading point
Marginal/conditional cannot be precomputed



Environment Map Parameterizations

Latitude/Longitude



Light probe



Cube map

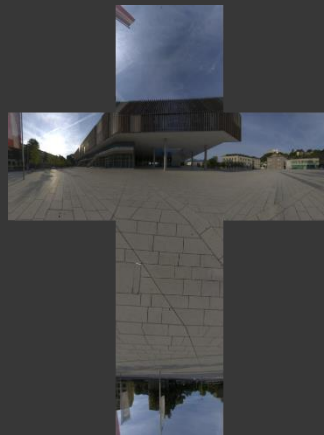

Environment Map Parameterizations

Latitude/Longitude



Light probe



Cube map



Visible regions **not rectangular** in these mappings

Environment Map Parameterizations

Latitude/Longitude



Light probe



Cube map



Rectified Coordinates

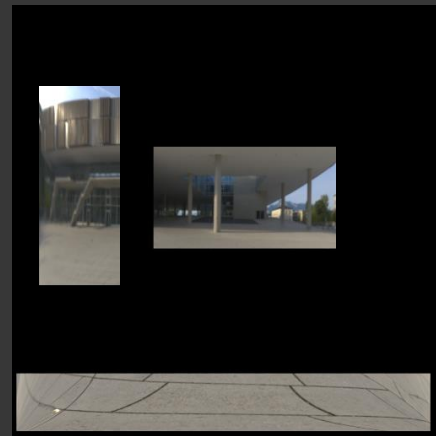

Visible regions **not rectangular** in these mappings
Let's create one in which they are!

Rectified Coordinates

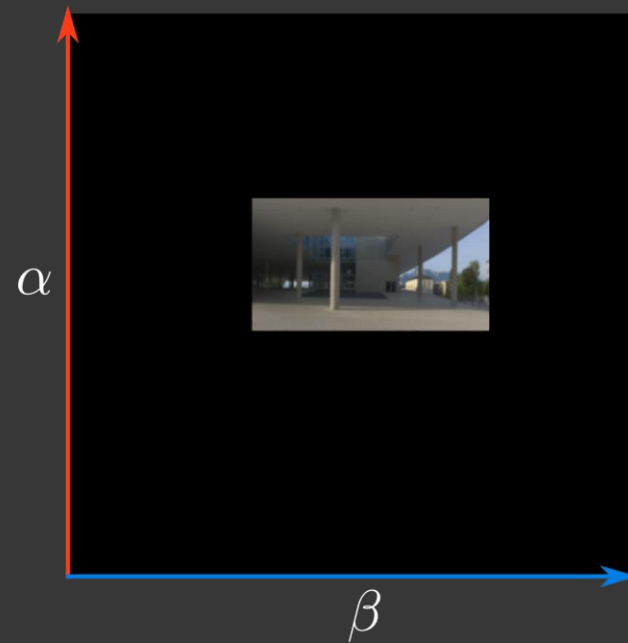

Rectified Coordinates

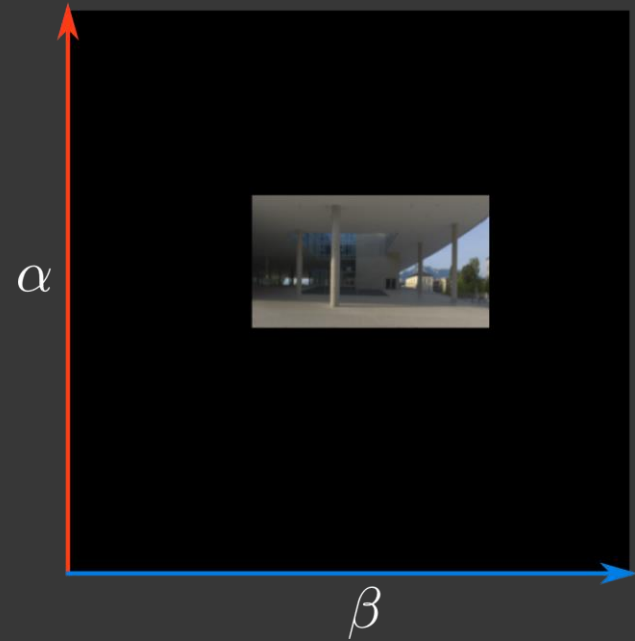
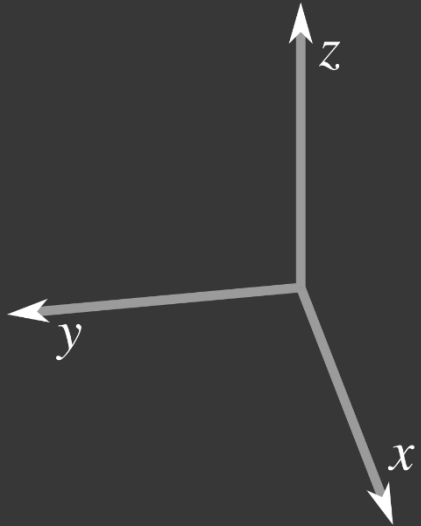

Rectified Coordinates

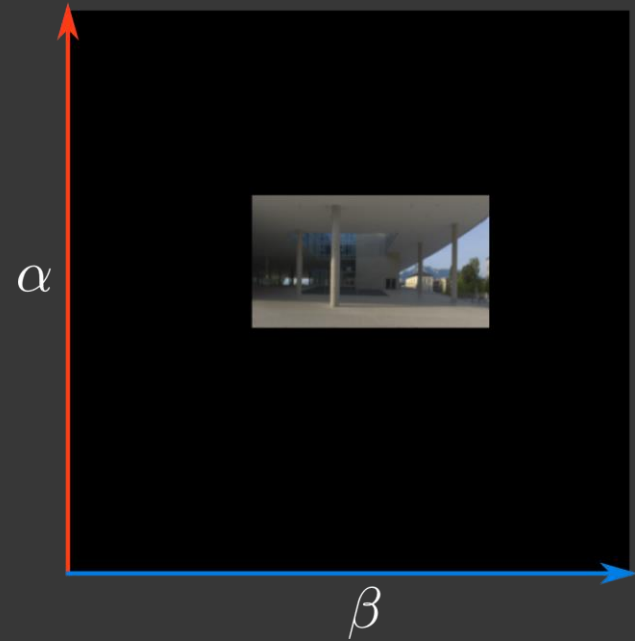
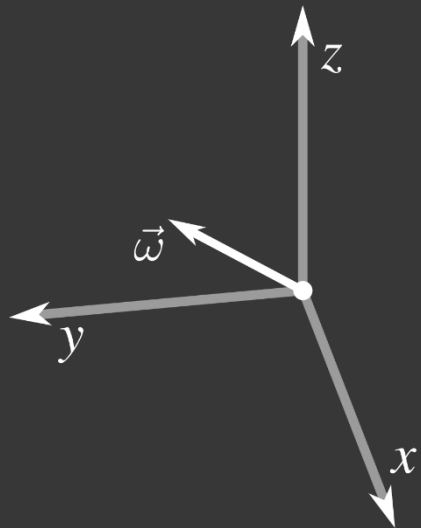

Rectified Coordinates

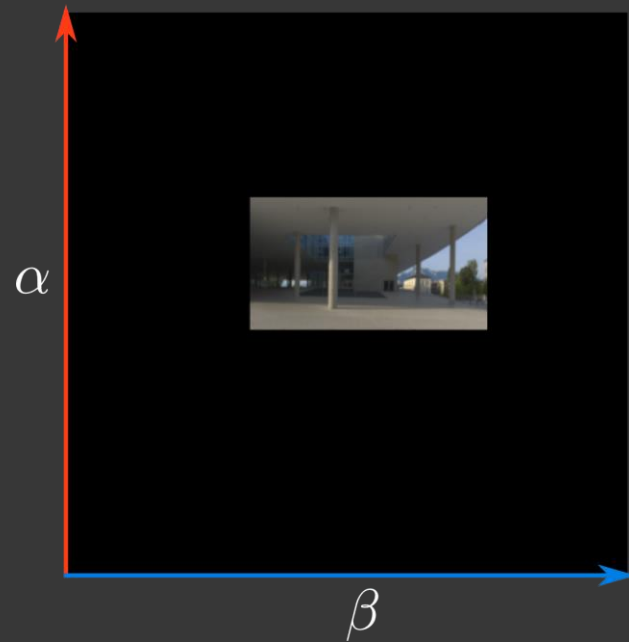
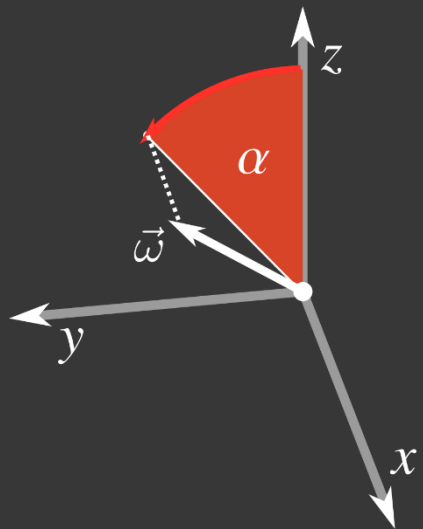

Rectified Coordinates

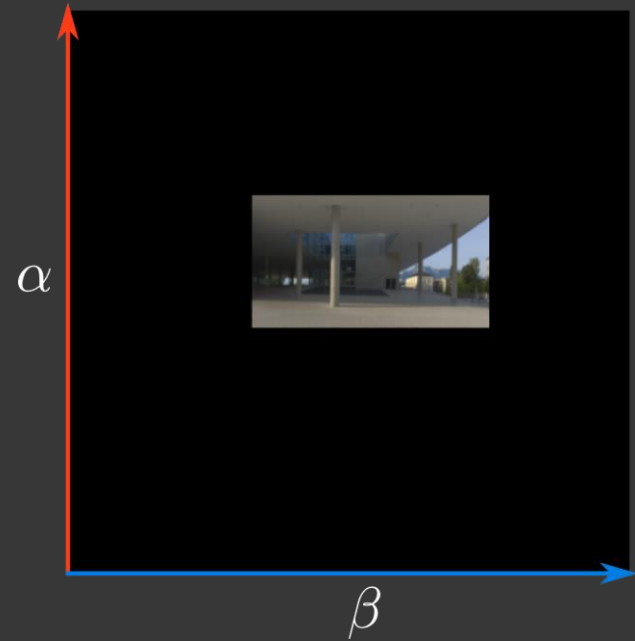
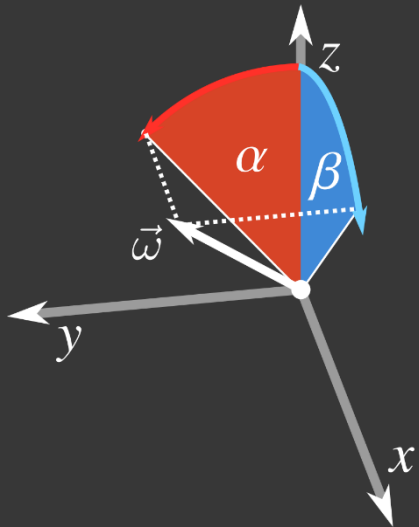

Rectified Coordinates

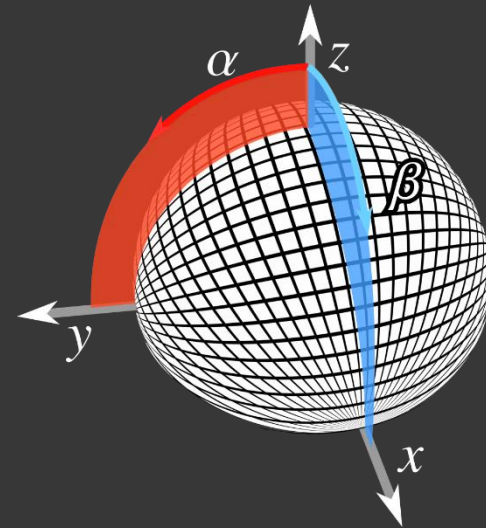
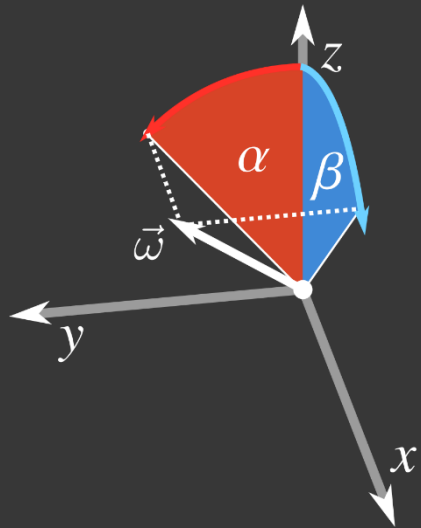

Rectified Coordinates

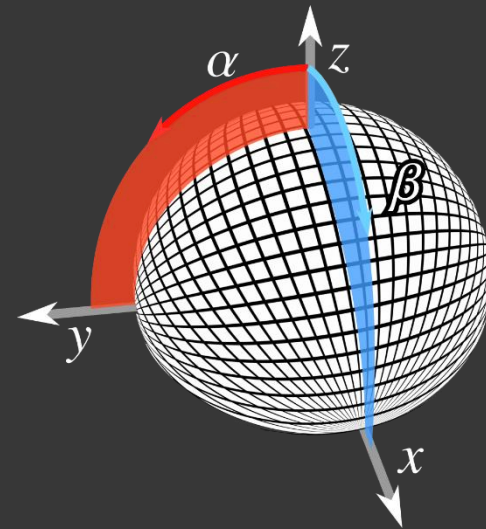
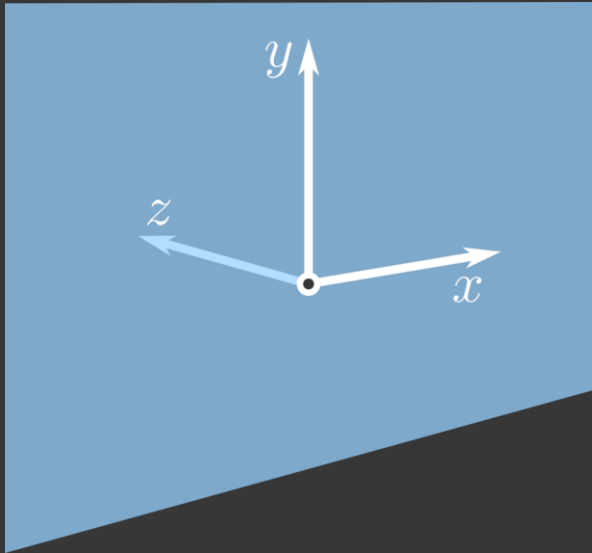

Parametrization is **aligned** with the portal

Rectified Coordinates

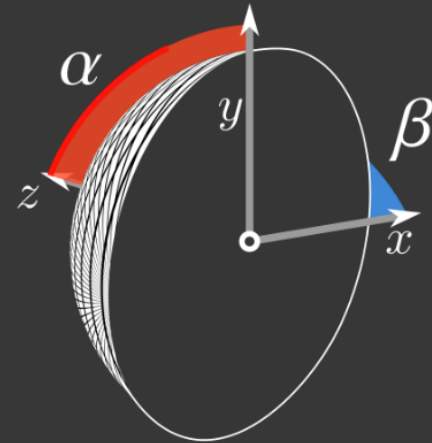
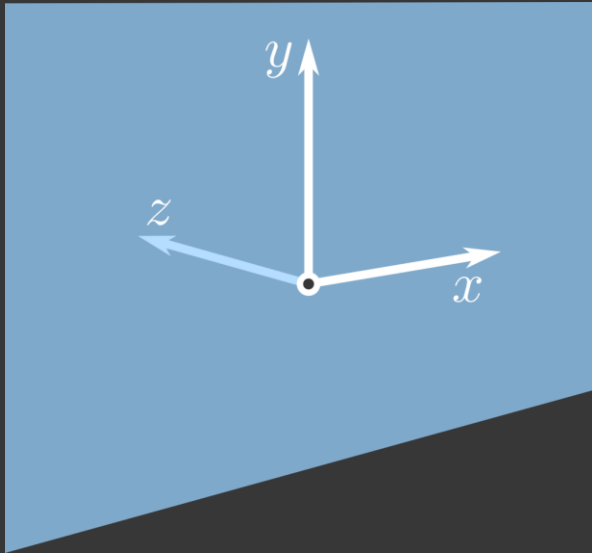

Parametrization is **aligned** with the portal

Rectified Coordinates

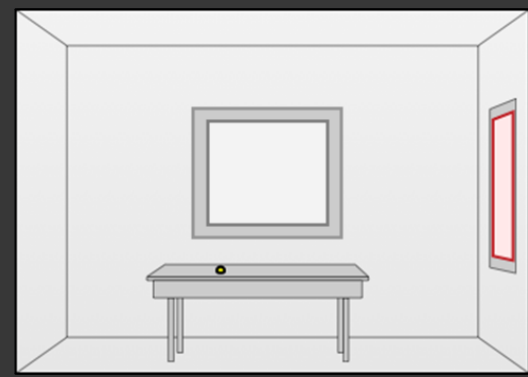
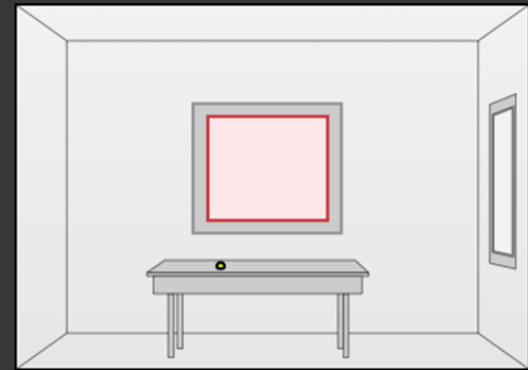
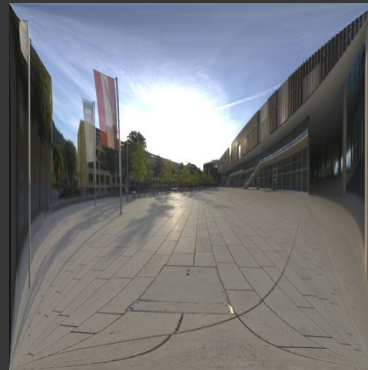

Need separate environment map **per portal**

Rectified Coordinates

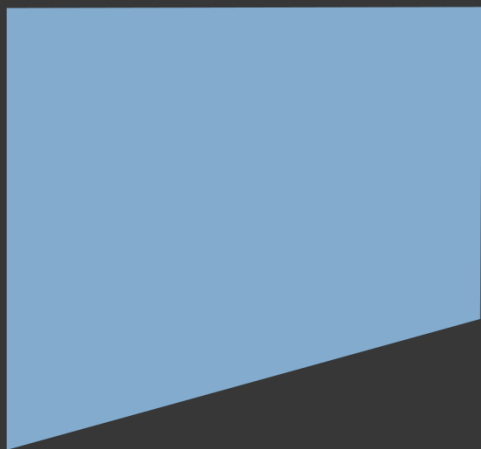

\circ_s

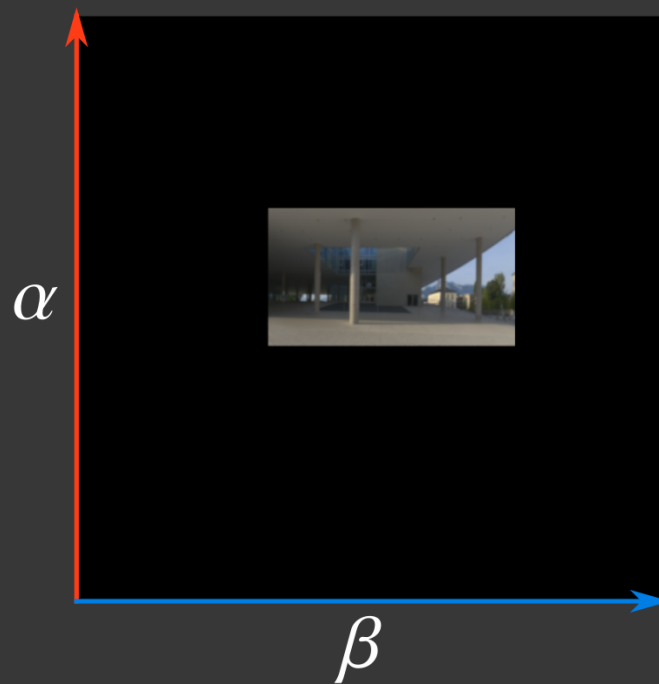

Rectified Coordinates

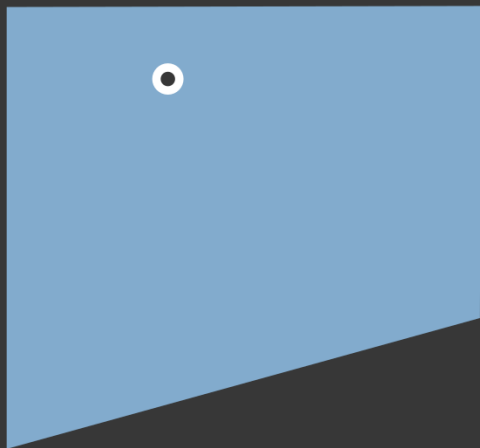

s

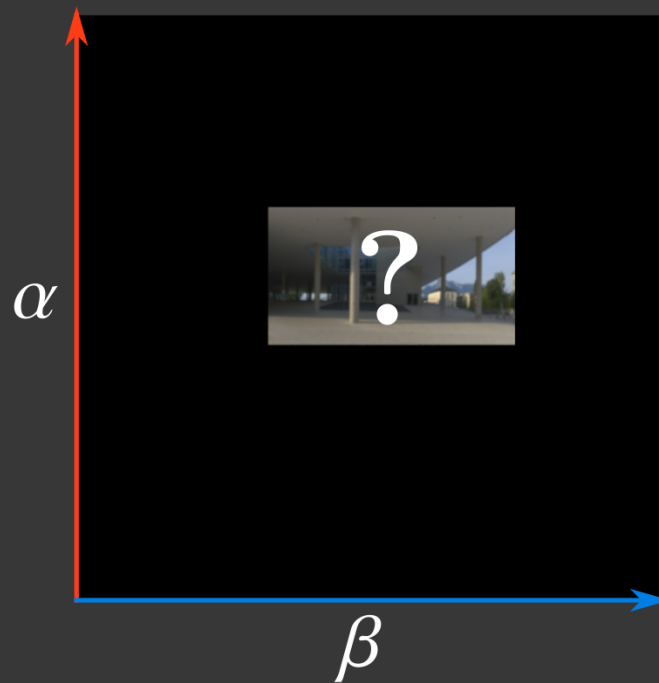

Rectified Coordinates

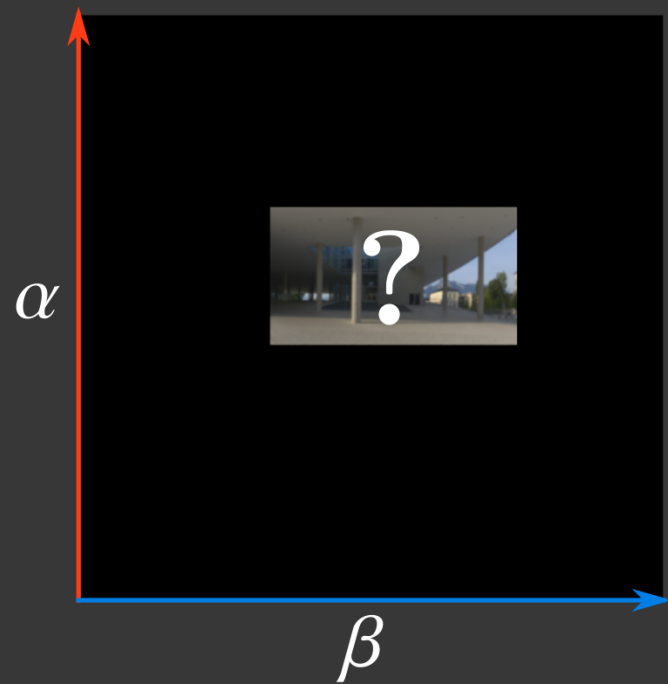
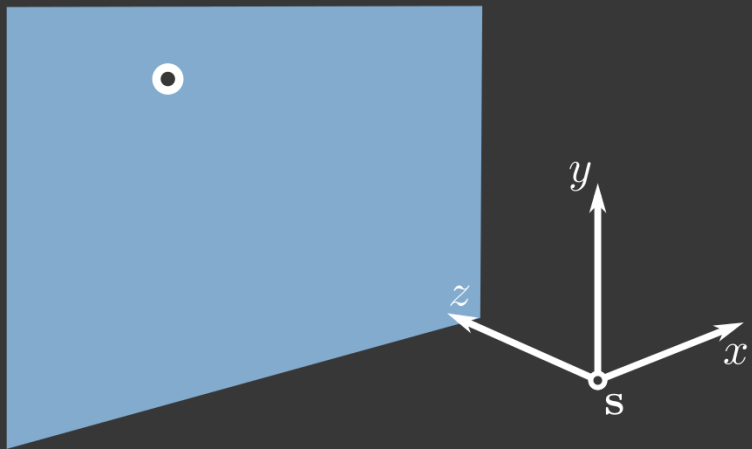

Rectified Coordinates

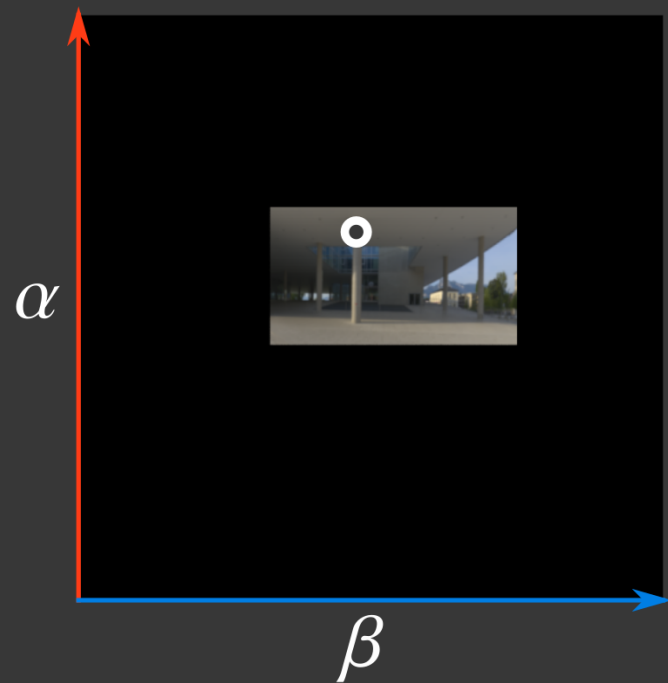
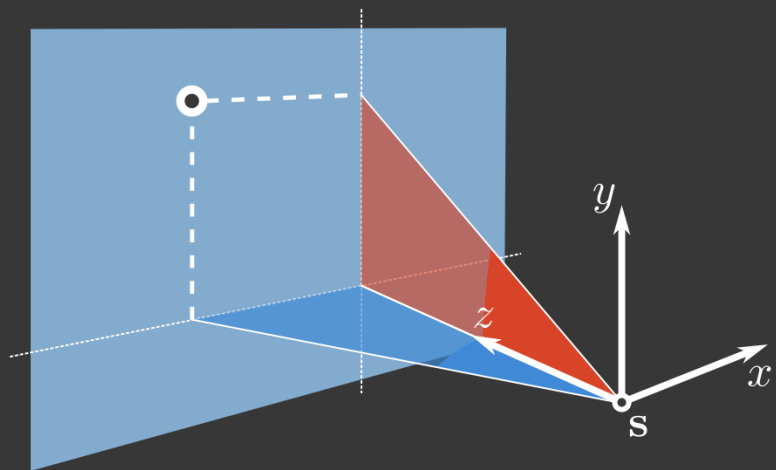

Rectified Coordinates

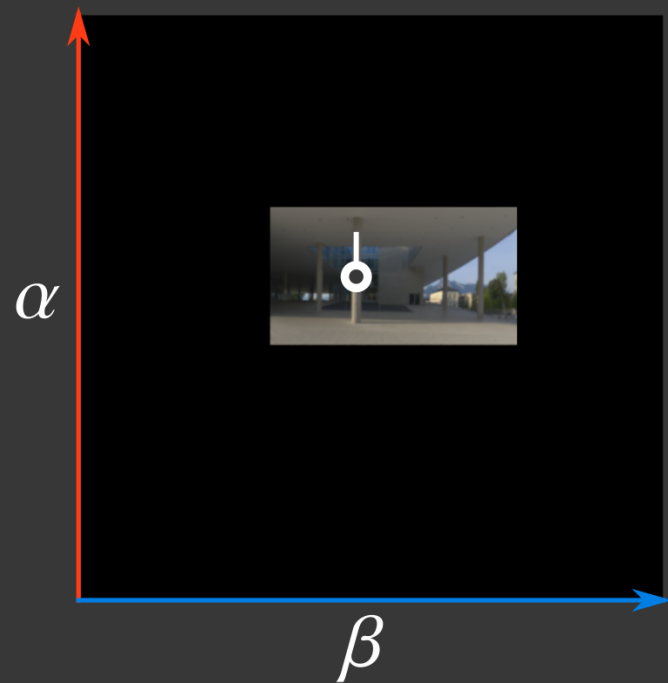
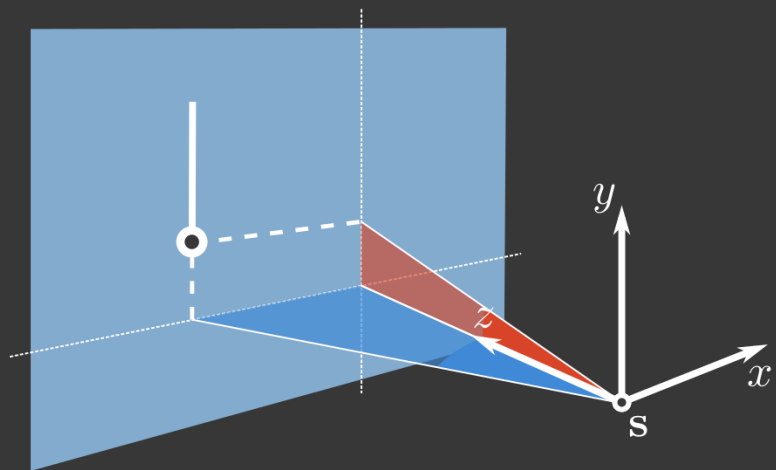

Rectified Coordinates

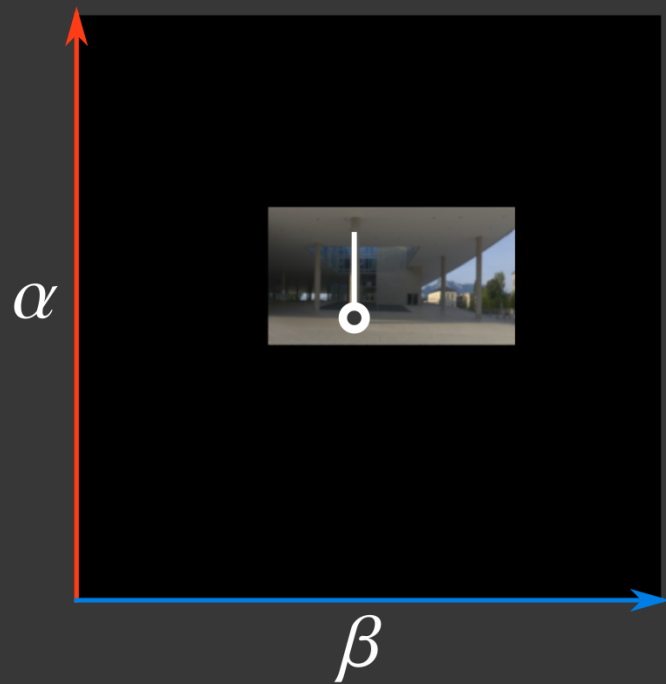
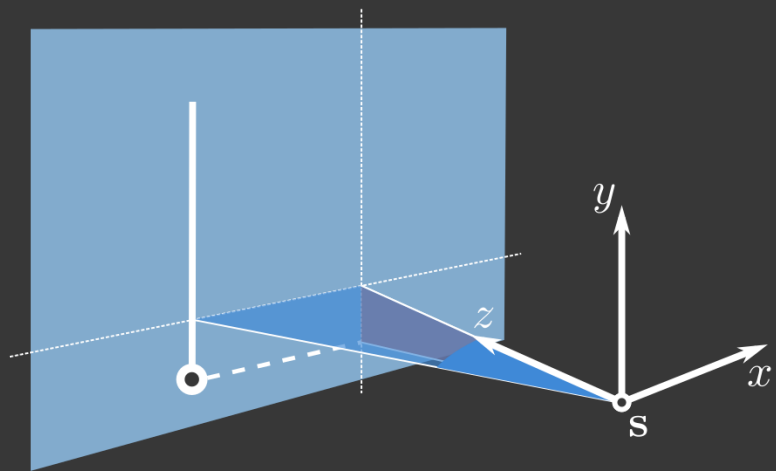

Rectified Coordinates

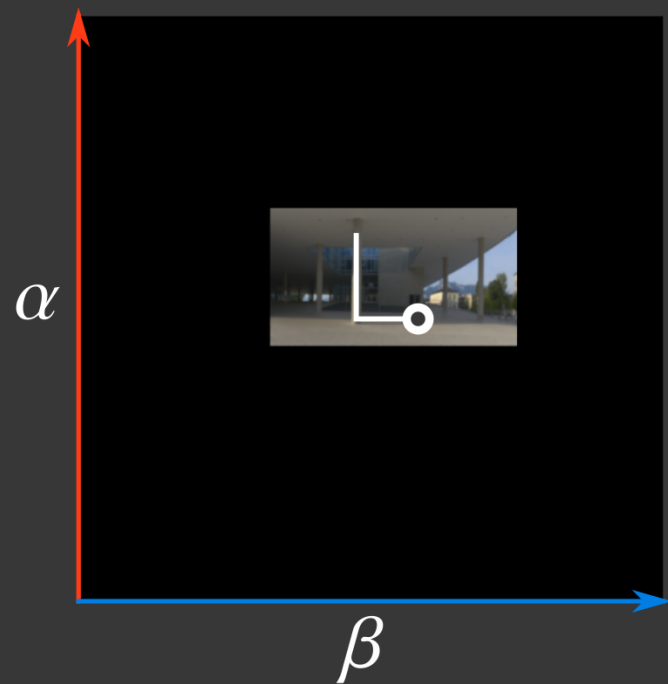
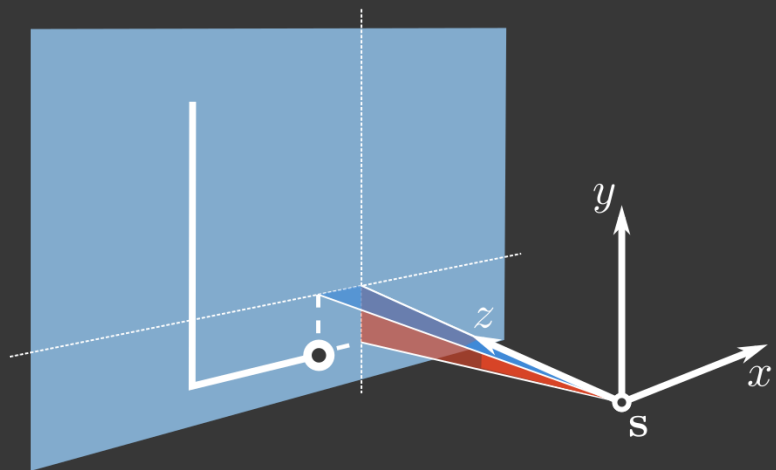

Rectified Coordinates

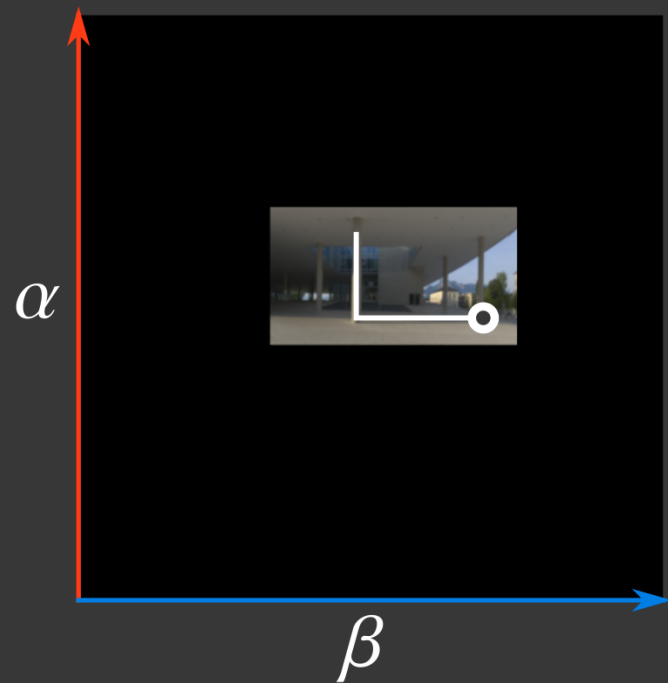
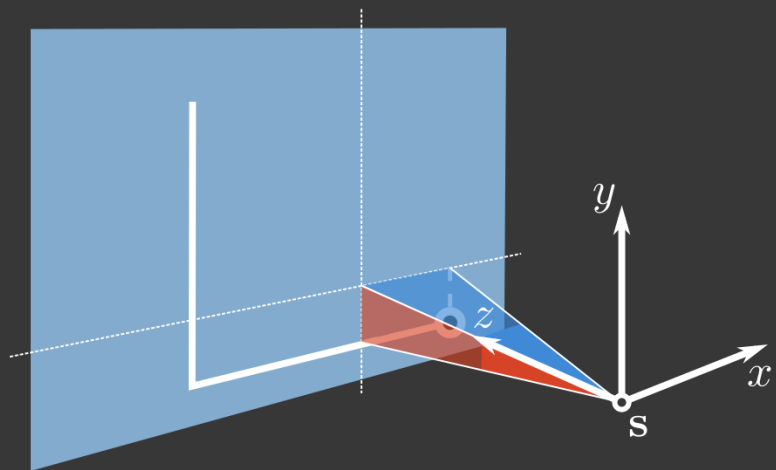

Rectified Coordinates

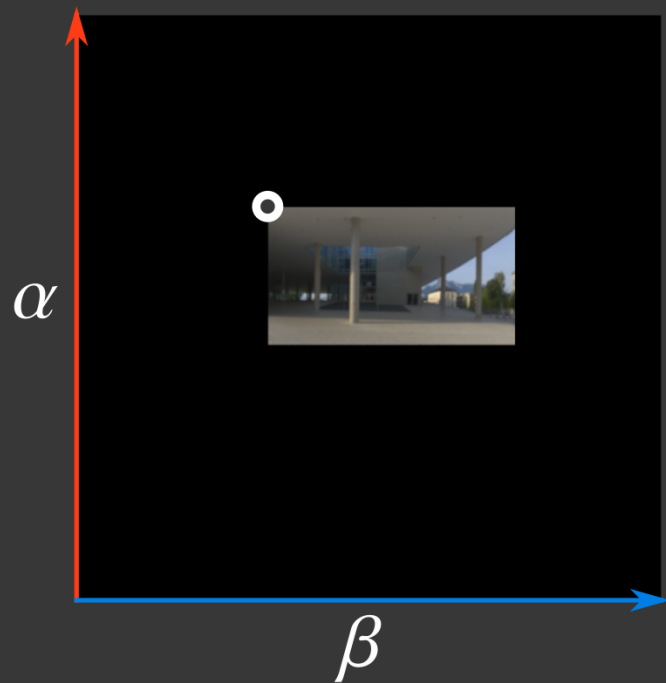
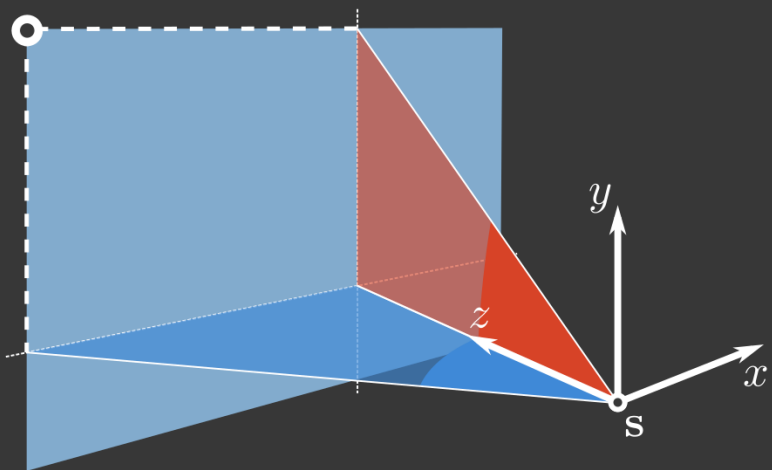

Rectified Coordinates

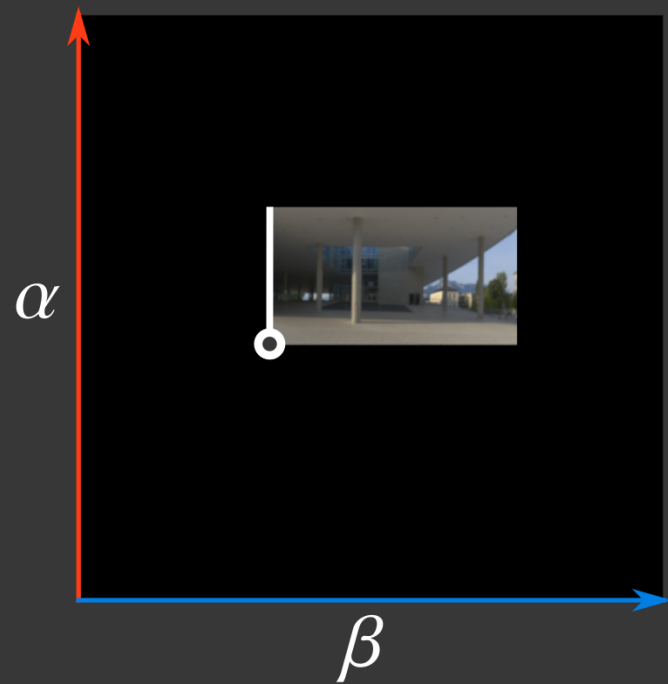
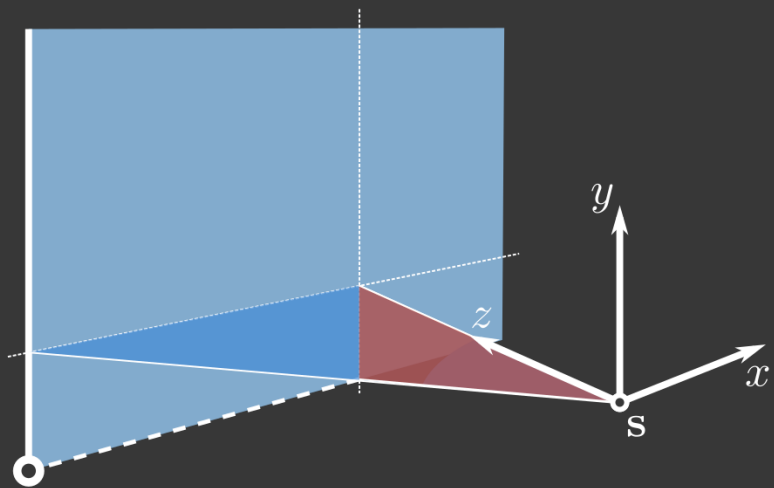

Rectified Coordinates

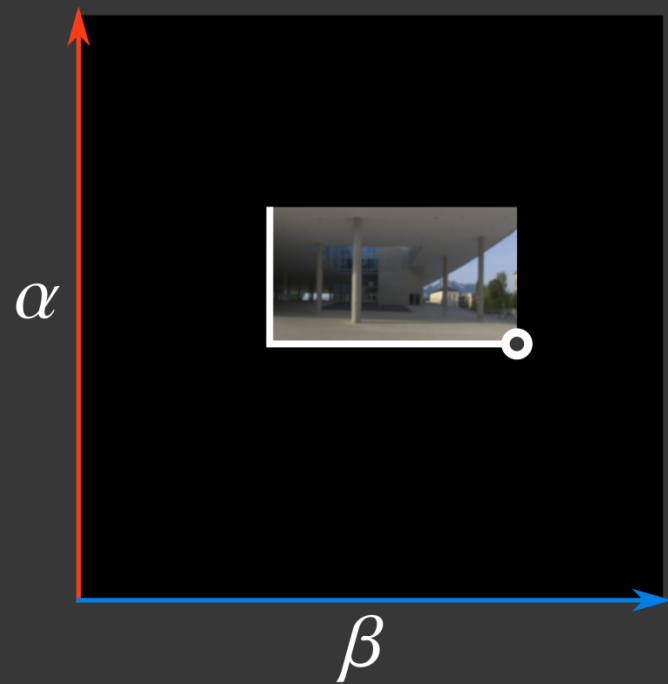
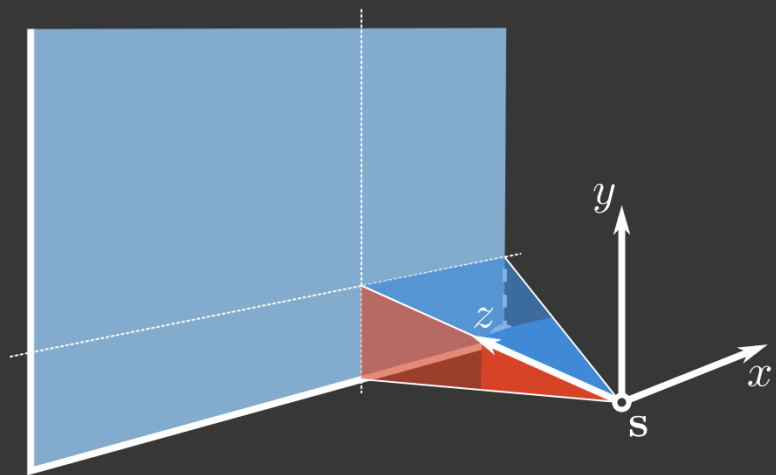

Rectified Coordinates

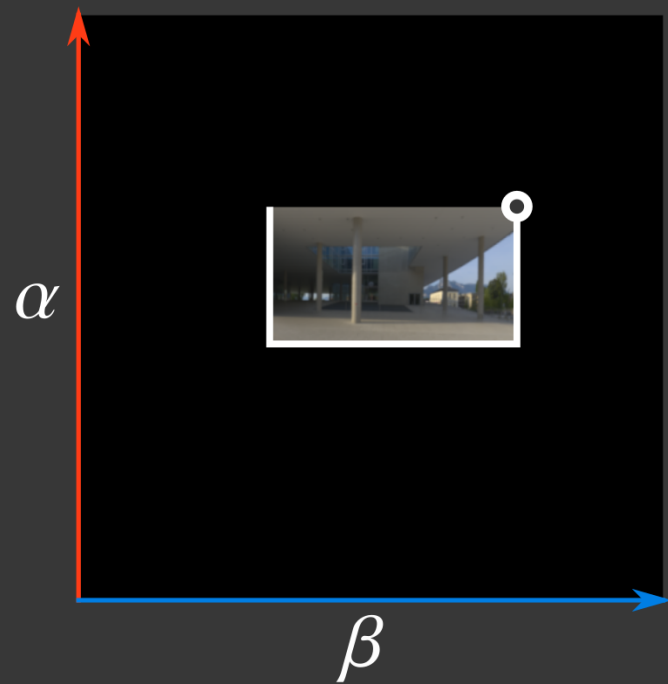
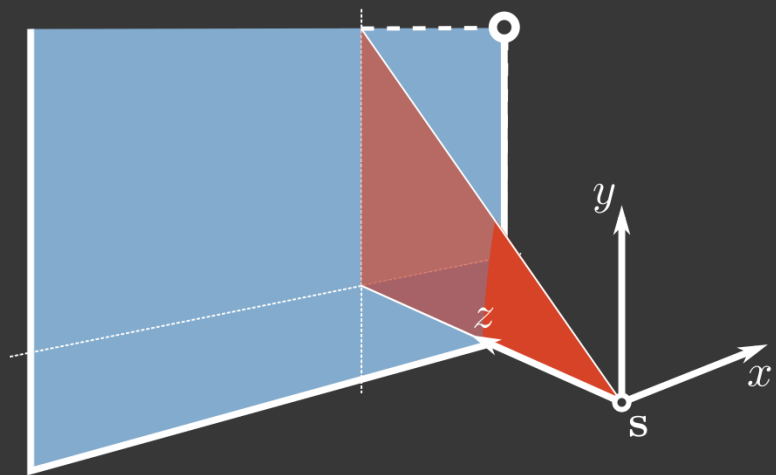

Rectified Coordinates

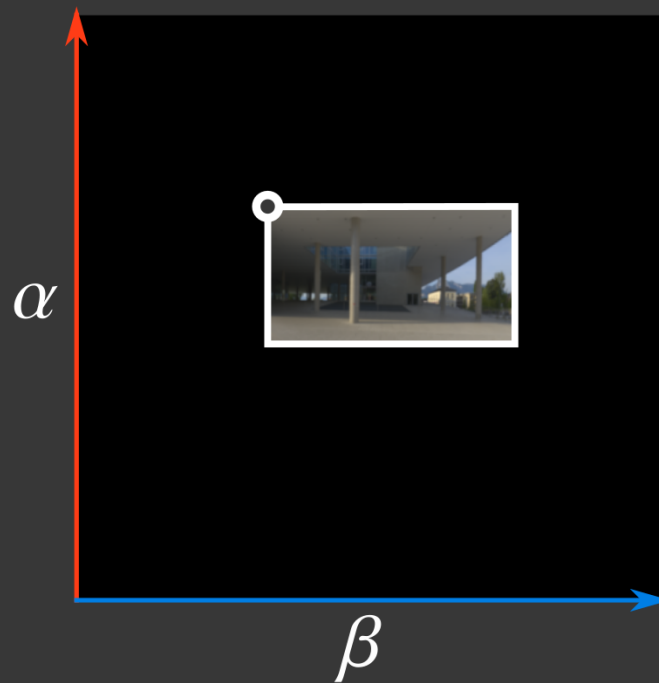
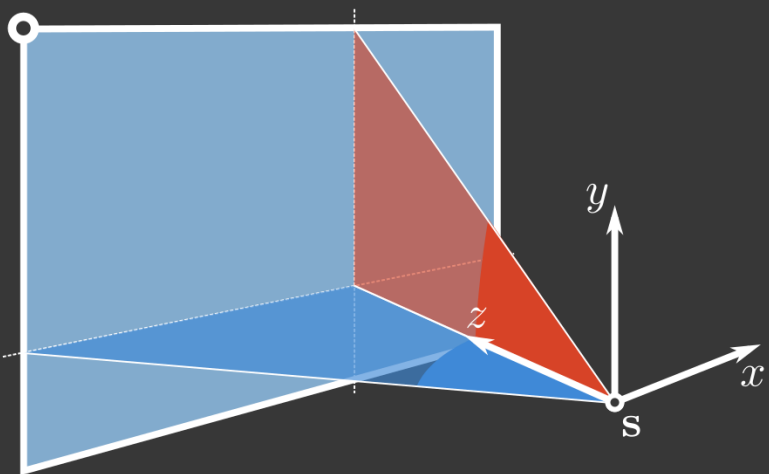

Portal-Masked Environment Map Sampling

Challenges:

- 1) Visible regions have complex shapes
Marginal/conditional decomposition difficult
- 2) Visible regions different for each shading point
Marginal/conditional cannot be precomputed



Portal-Masked Environment Map Sampling

Challenges:

- 1) Visible regions have complex shapes
Marginal/conditional decomposition difficult
- 2) Visible regions different for each shading point
Marginal/conditional cannot be precomputed



Sampling the Visible Region

- 1) Construct marginal/conditional distribution
- 2) Invert marginal/conditional distribution

Marginal Distribution

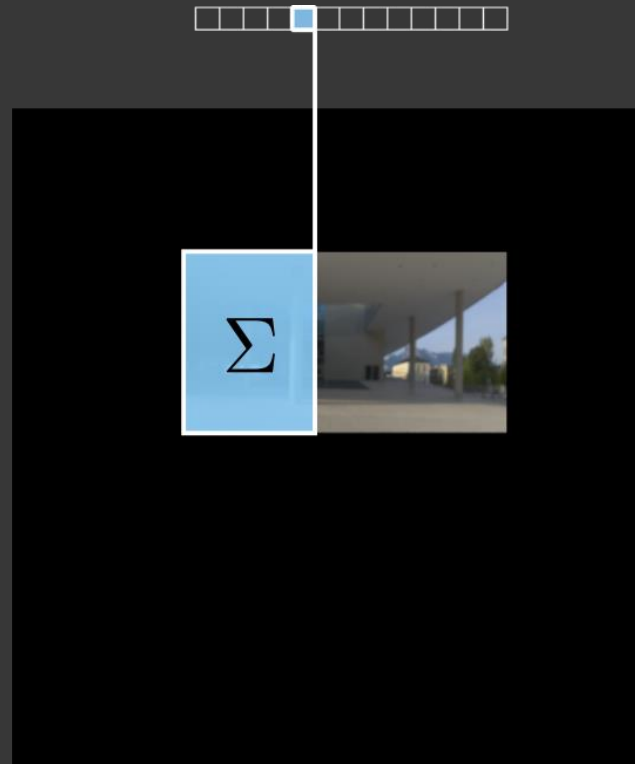

Marginal Distribution

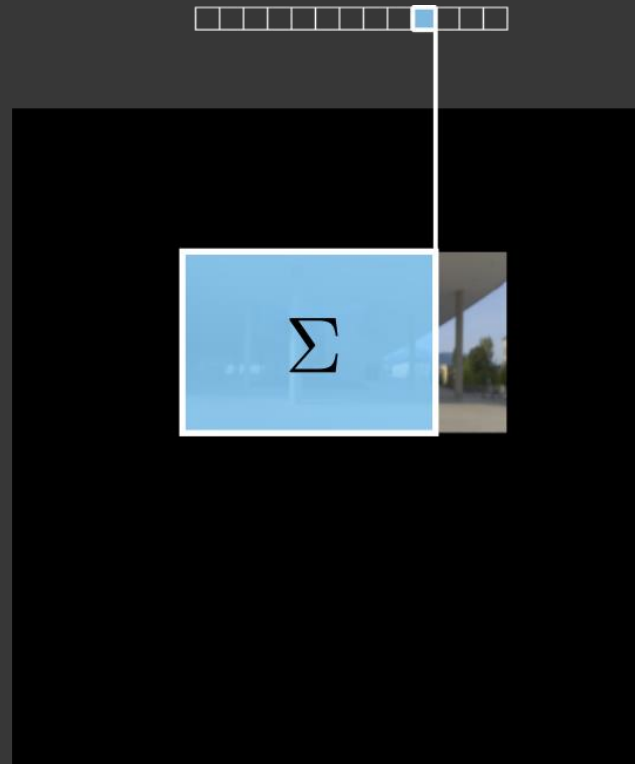

Marginal Distribution

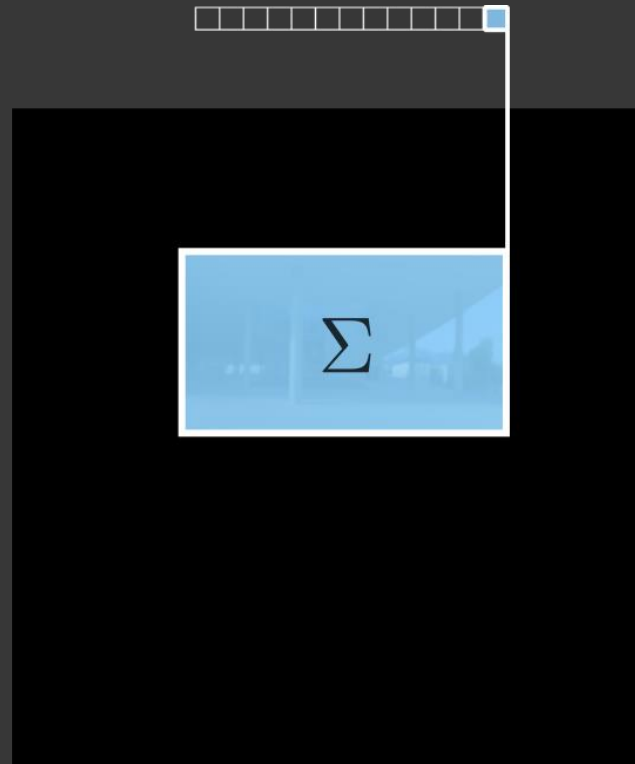

Marginal Distribution

Precompute summed-area table instead [Crow '84]

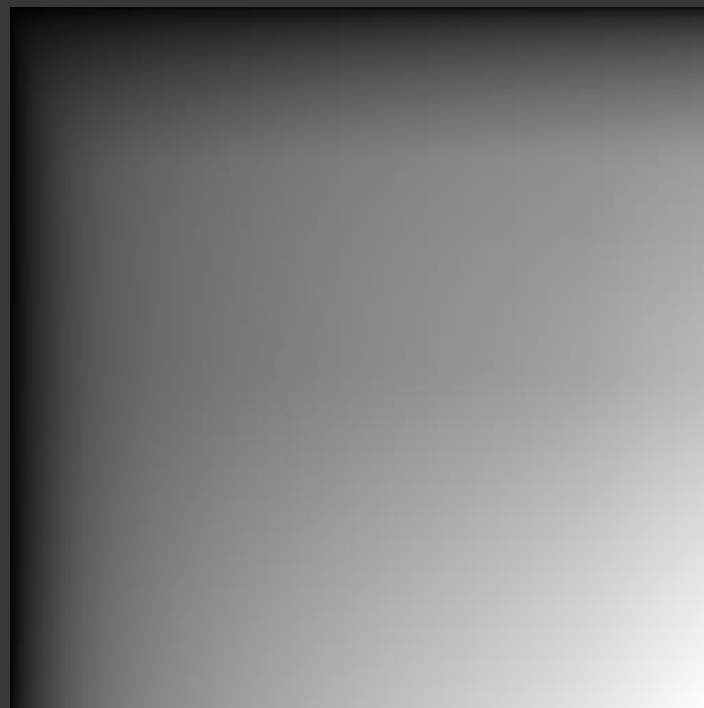
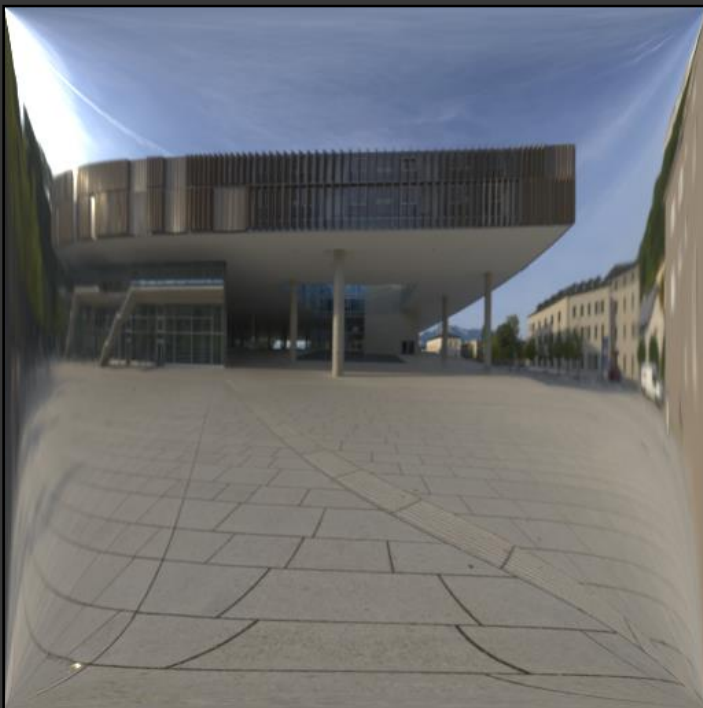

Sampling the Visible Region

1) Construct marginal/conditional distributions

Precompute summed-area table instead [Crow '84]

2) Invert marginal/conditional distributions

Inverting the Marginal Distribution

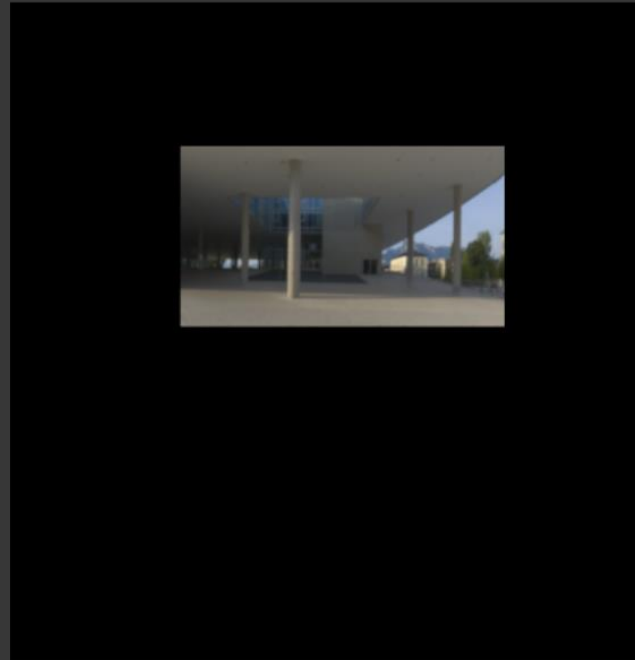

Inverting the Marginal Distribution

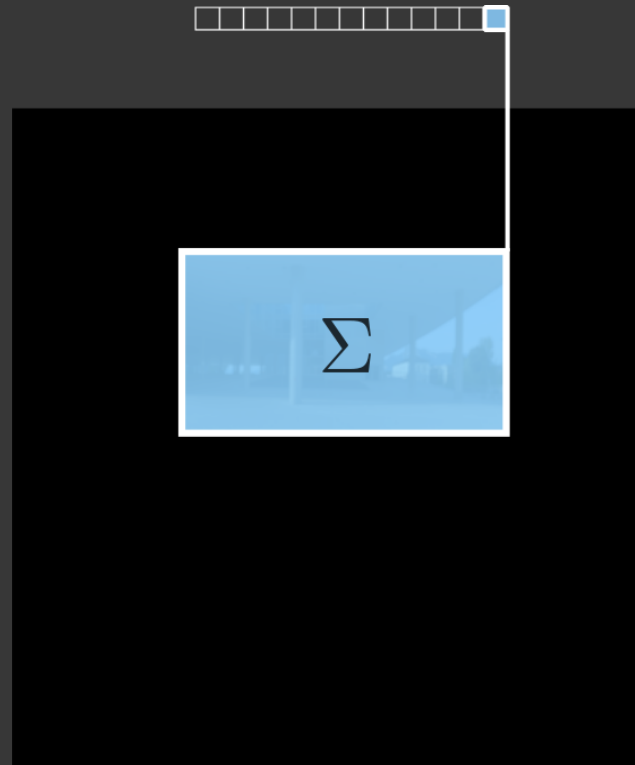

Inverting the Marginal Distribution

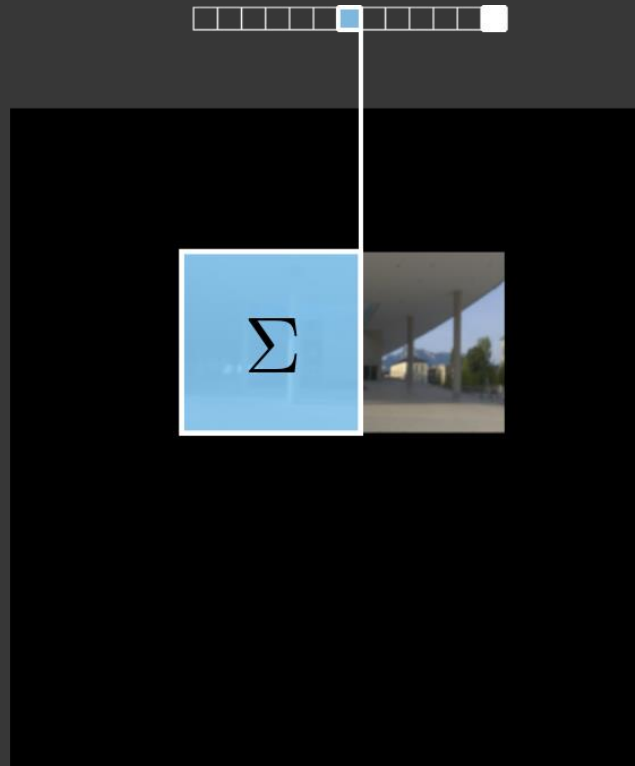

Inverting the Marginal Distribution

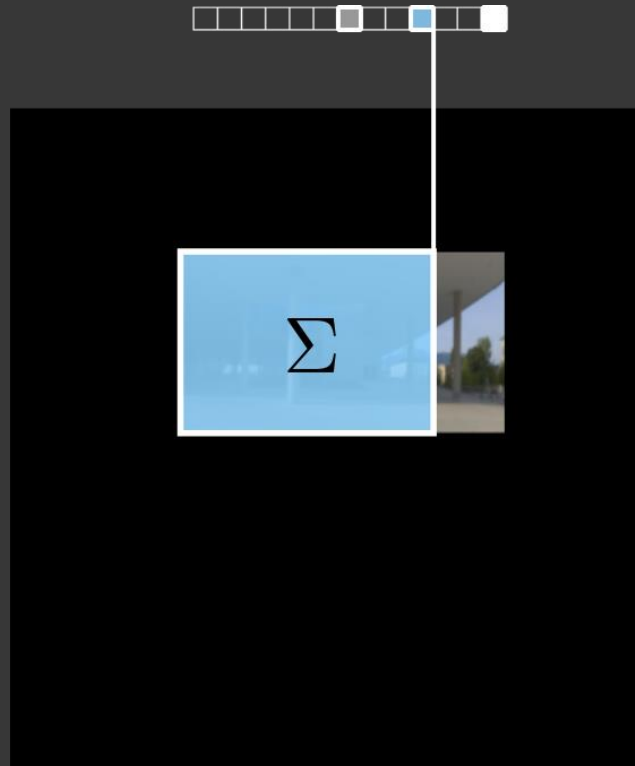

Inverting the Marginal Distribution

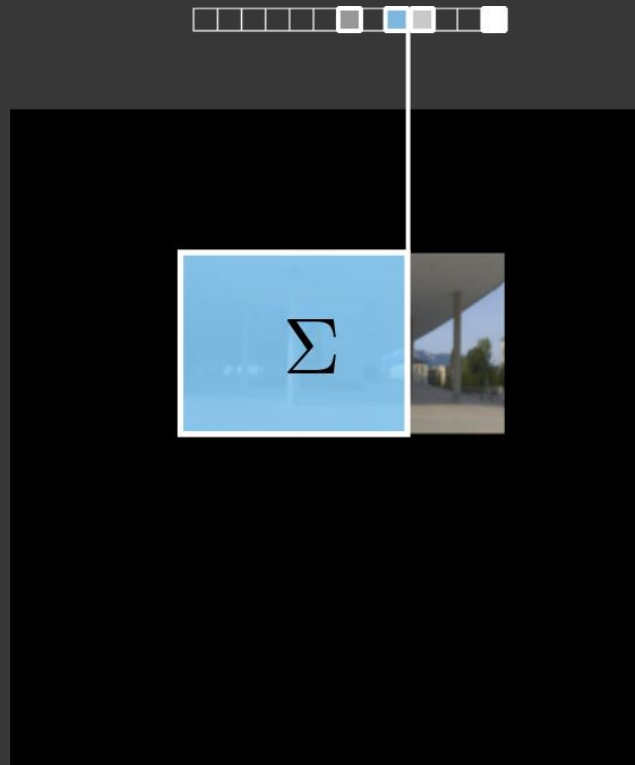

Inverting the Marginal Distribution

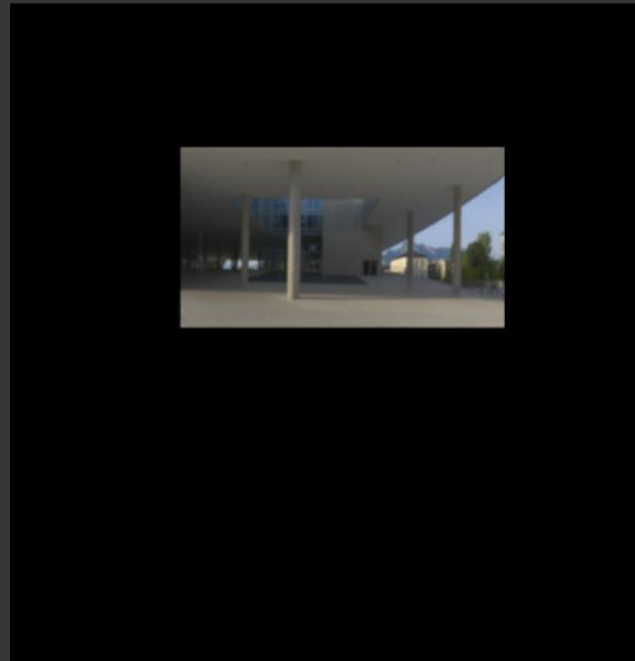

Sampling the Visible Region

1) Construct marginal/conditional distributions

Precompute summed-area table instead [Crow '84]

2) Invert marginal/conditional distributions

Use bisection algorithm for logarithmic complexity

Results

Results

Comparison of:

- a) Environment map sampling
- b) Portal solid angle sampling [Ureña et al. 2013]
- c) Multiple importance sampling of a) and b) [Veach 1998]
- d) Ours

at equal sample count (8spp)

All methods combined with 1 BRDF sample using MIS









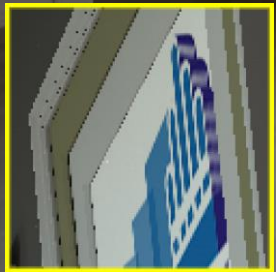
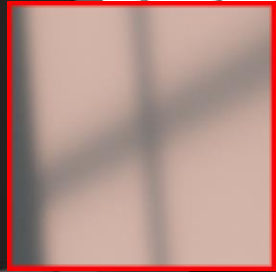

Reference
RMSE

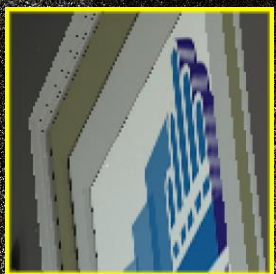
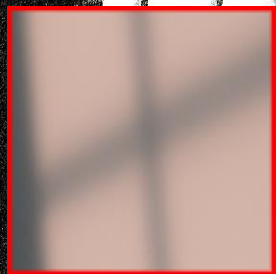

Reference
RMSE

Env. Map
0.23

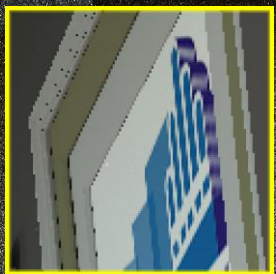
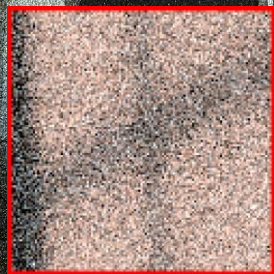
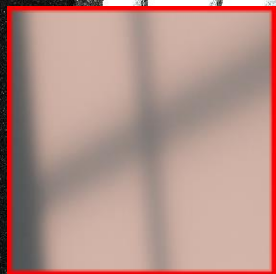

Reference
RMSE

Env. Map
0.23

Portal S.Angle
3.31

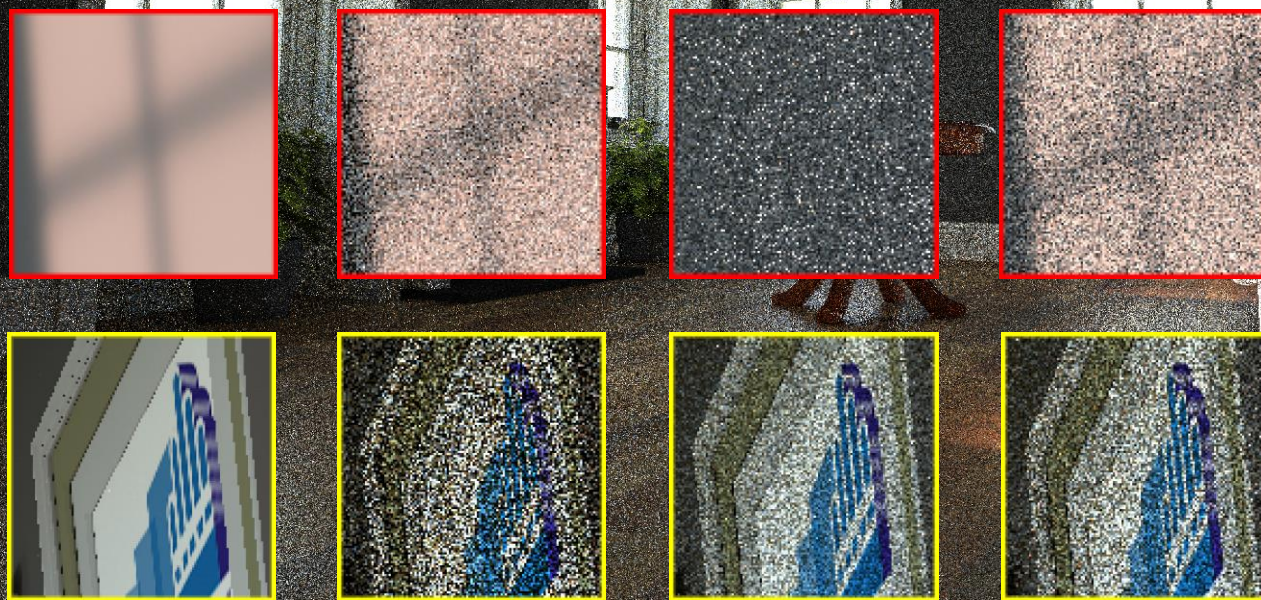

Reference
RMSE

Env. Map
0.23

Portal S.Angle
3.31

MIS
0.26

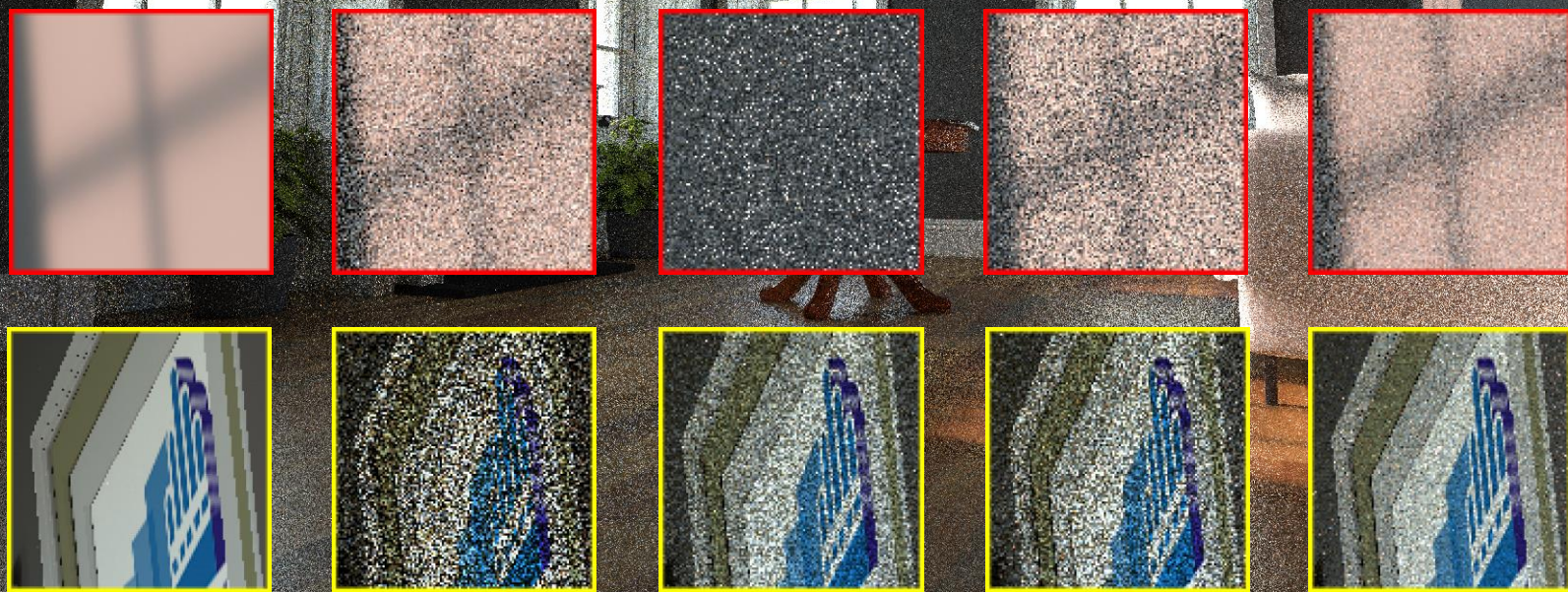

Reference
RMSE

Env. Map
0.23

Portal S.Angle
3.31

MIS
0.26

Ours
0.16









Reference
RMSE

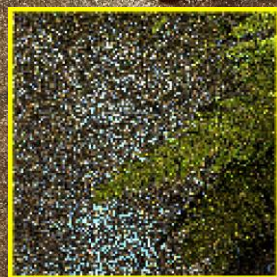
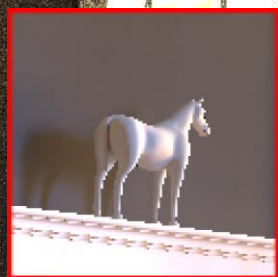

Reference
RMSE

Env. Map
0.59

Portal S.Angle
0.74

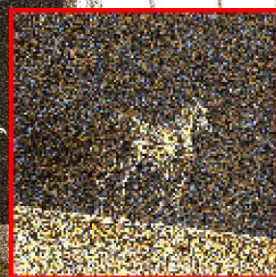
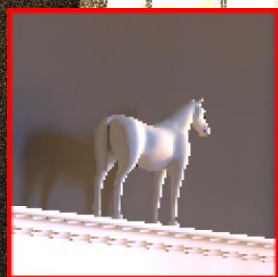

Reference
RMSE

Env. Map
0.59

Portal S.Angle
0.74

MIS
0.60

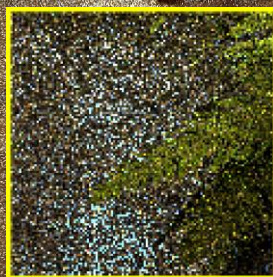
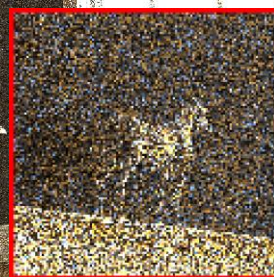
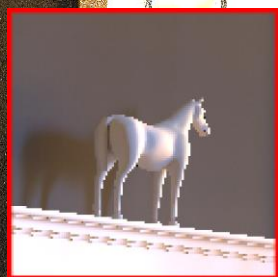

Reference
RMSE

Env. Map
0.59

Portal S.Angle
0.74

MIS
0.60

Ours
0.34

More Results

Please see supplementary material

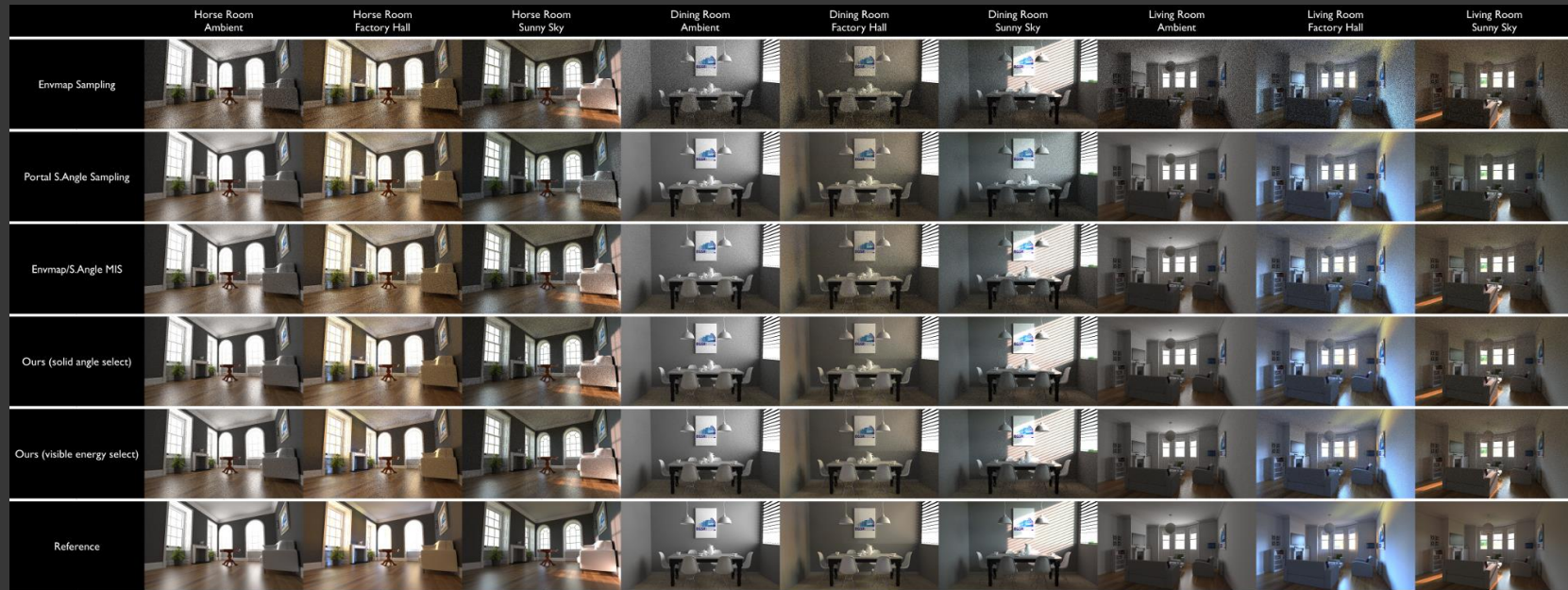

By the numbers

Equal time:

- 33% less shadow rays than Env. Map sampling

Equal quality:

- 2x – 8x speedup w.r.t. Env. Map sampling
- 2x – 5x speedup w.r.t. Env Map/Portal MIS

Area lights with directional profile

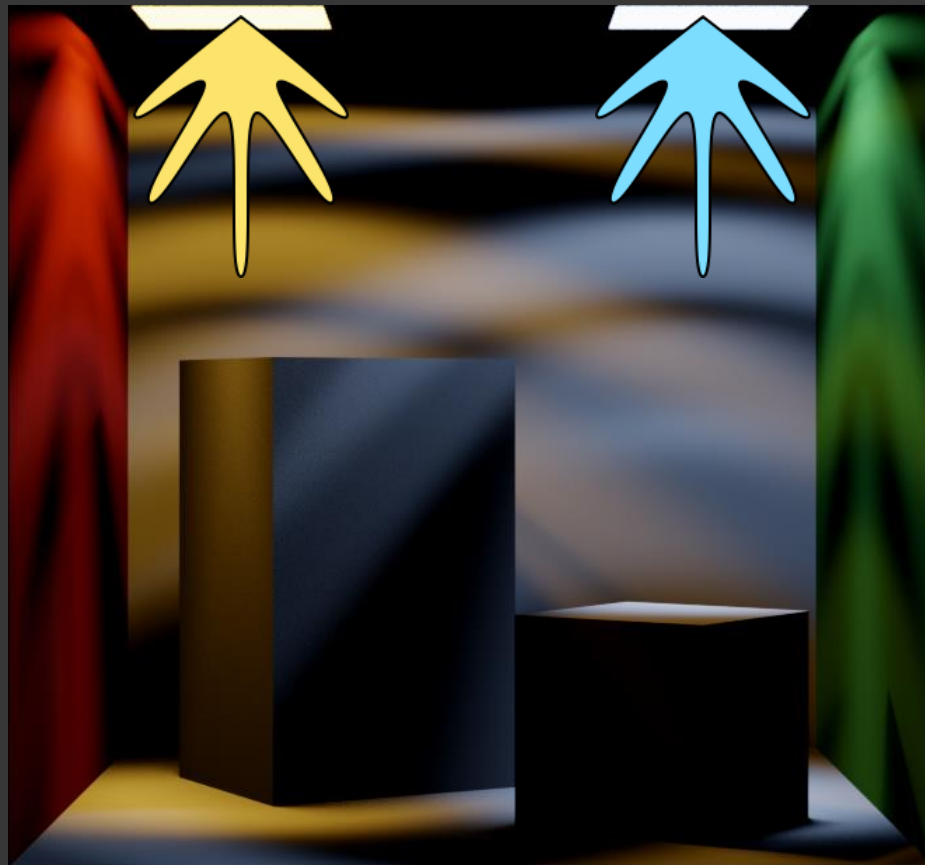

Area lights with directional profile

Uniform Solid Angle Sampling

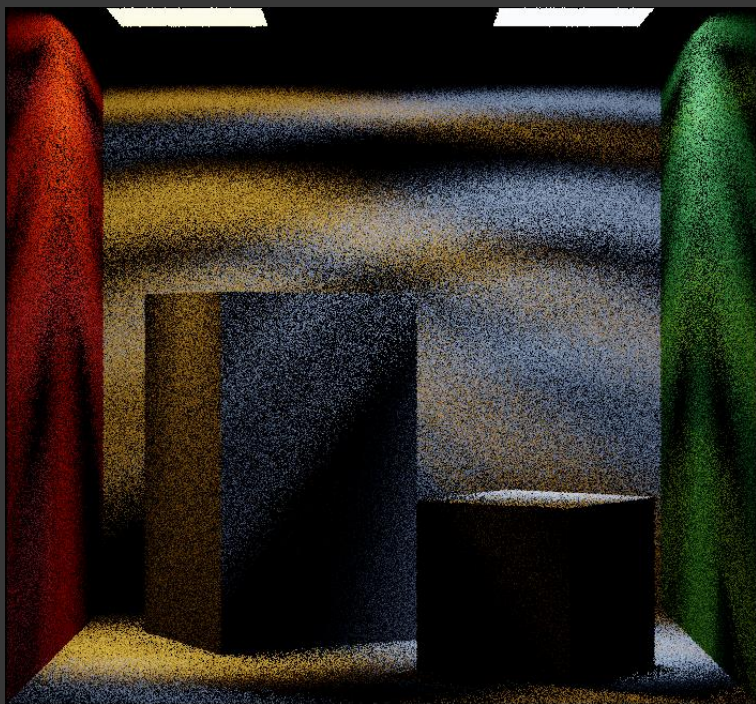

Ours

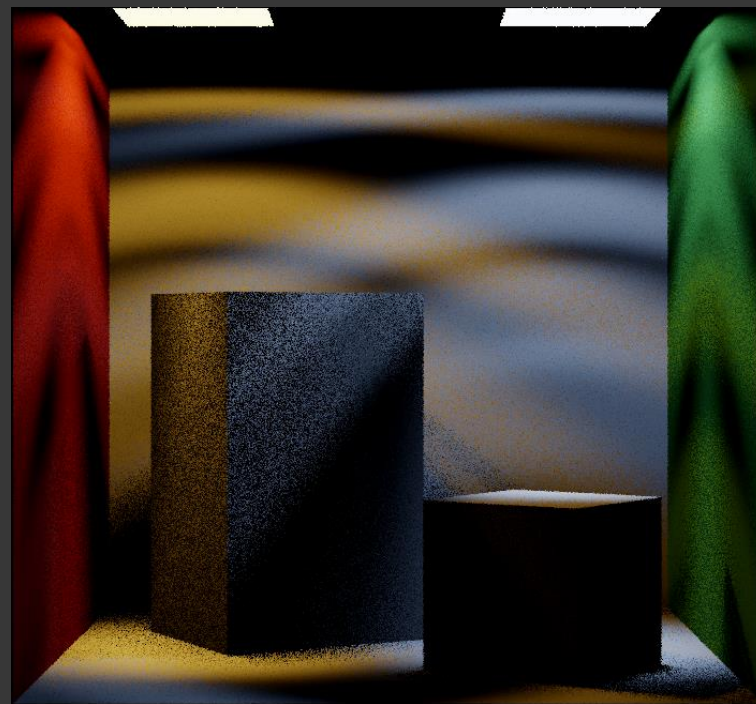

10x speedup

Conclusion

Take away from this talk:

- Can importance sample visibility x Env. Map
- Need single (precomputed) SAT per portal
- Easy to implement!

Conclusion

Take away from this talk:

- Can importance sample visibility \times Env. Map
- Need single (precomputed) SAT per portal
- Easy to implement!

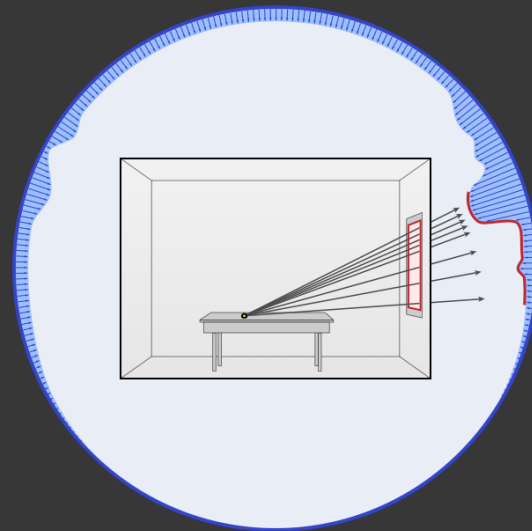

Conclusion

Take away from this talk:

- Can importance sample visibility \times Env. Map
- Need single (precomputed) SAT per portal
- Easy to implement!

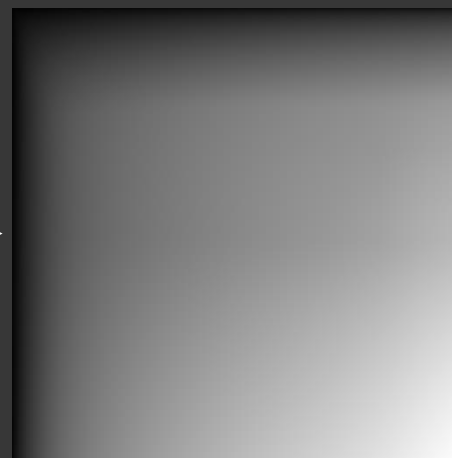
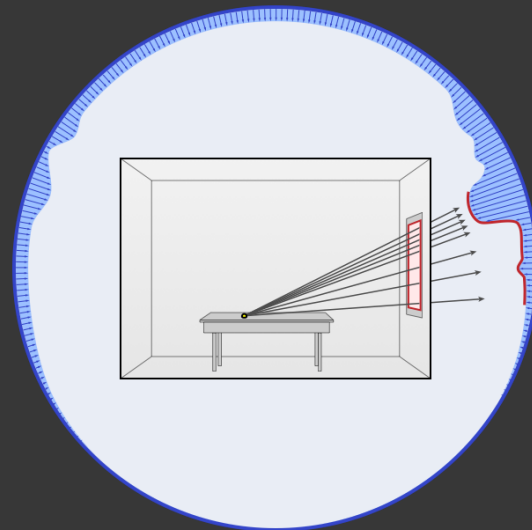

Conclusion

Take away from this talk:

- Can importance sample visibility \times Env. Map
- Need single (precomputed) SAT per portal
- Easy to implement!

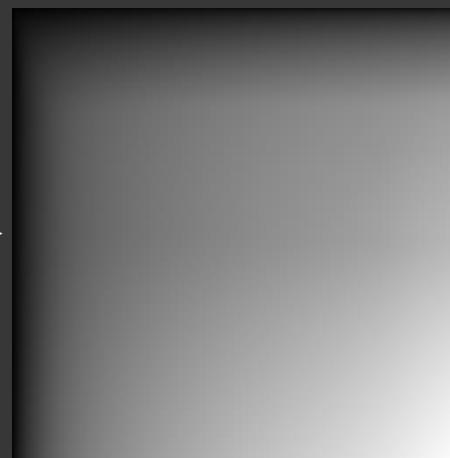
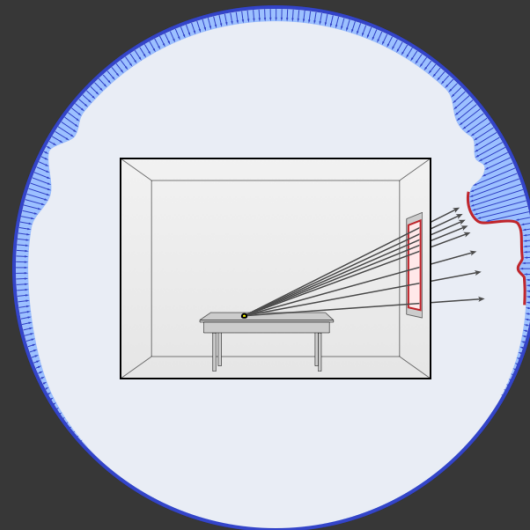

Limitations

- Needs a portal to work

Limitations

- Needs a portal to work
- Only considers visibility through a rectangle



Limitations

- Needs a portal to work
- Only considers visibility through a rectangle

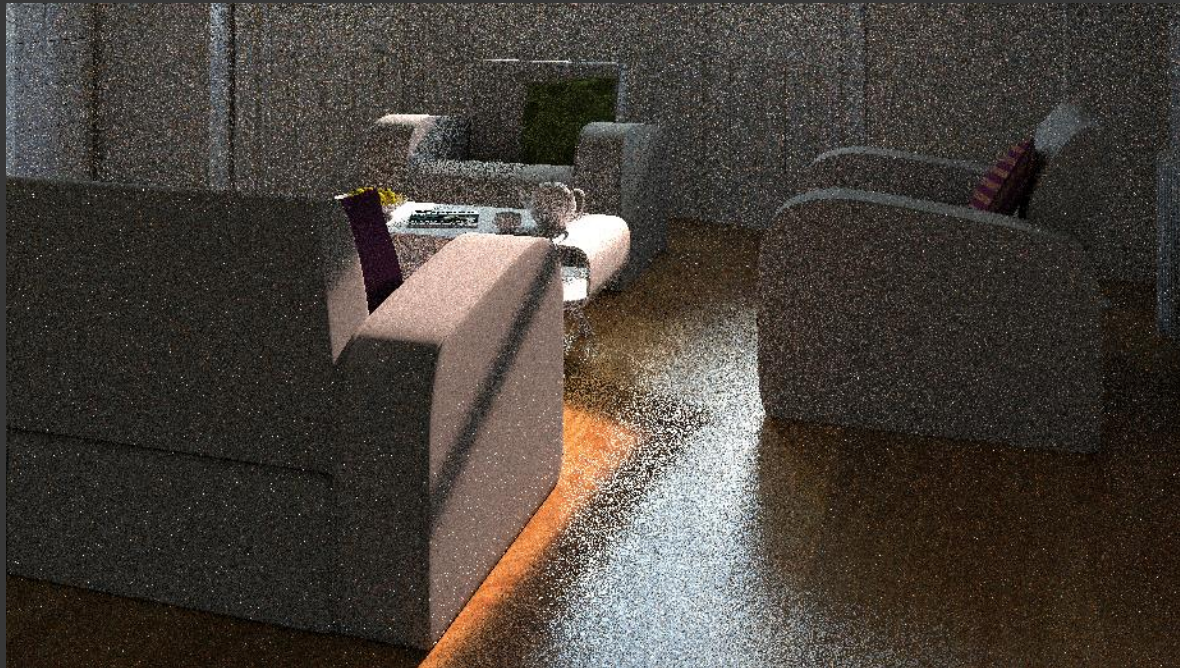

Future Work

Incorporate BRDF:

Combine with product sampling techniques

[Burke et al.]

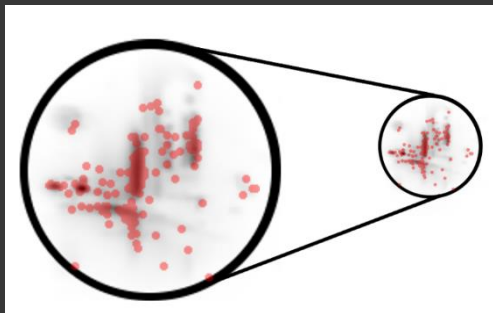

[Clarberg et al.]



[Cline et al.]

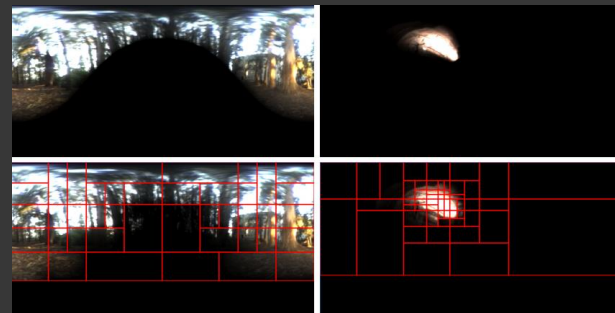

Thanks!

Acknowledgements:

- Environment maps: Bernhard Vogl, <http://openfootage.net>
- Scenes: Jay Hardy, Wayne

Bonus Slides

Sampling multiple portals

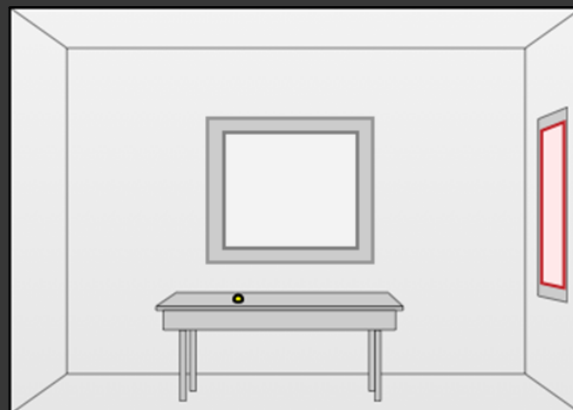
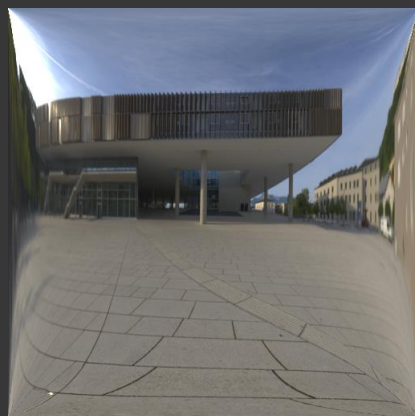
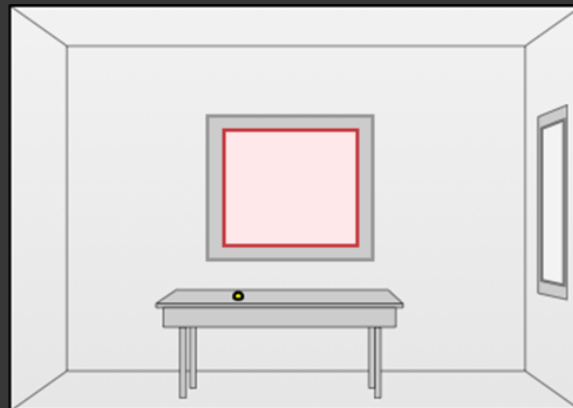
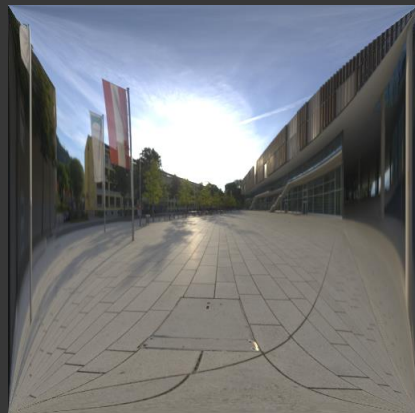

Sampling multiple portals

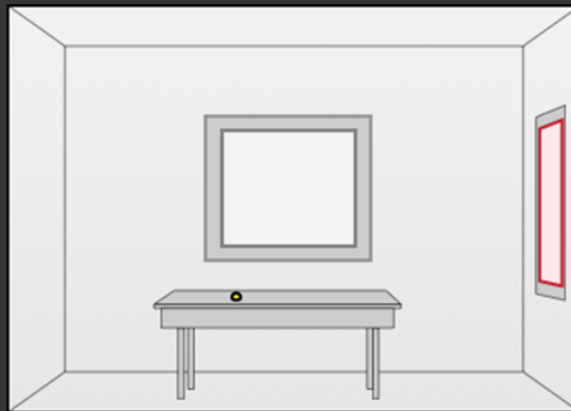
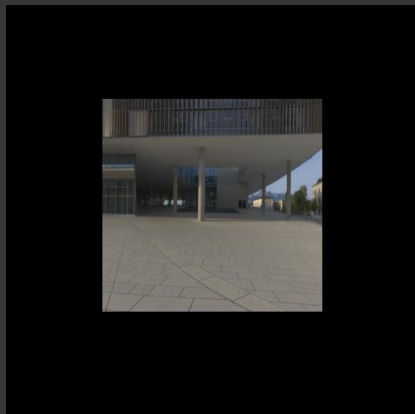
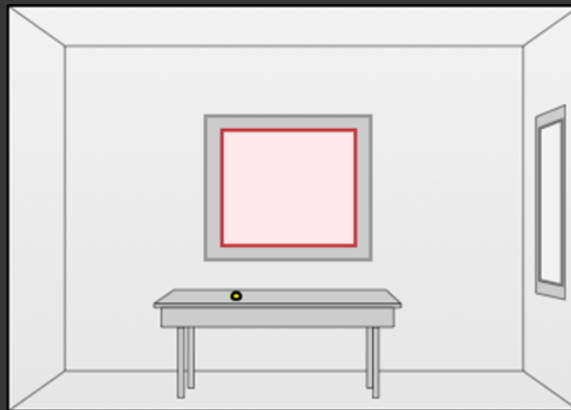

Sampling multiple portals

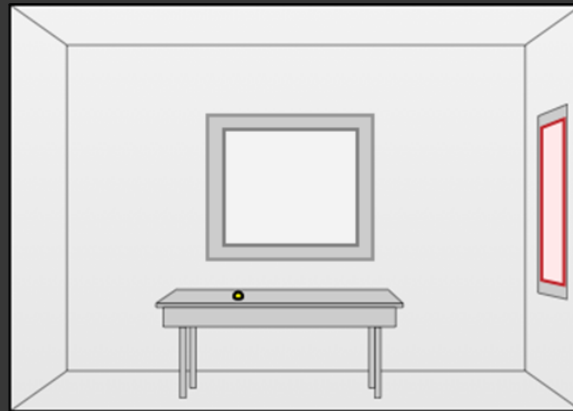
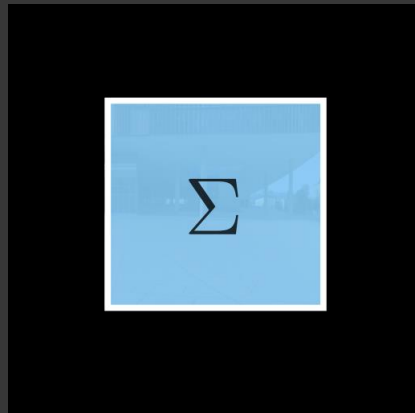
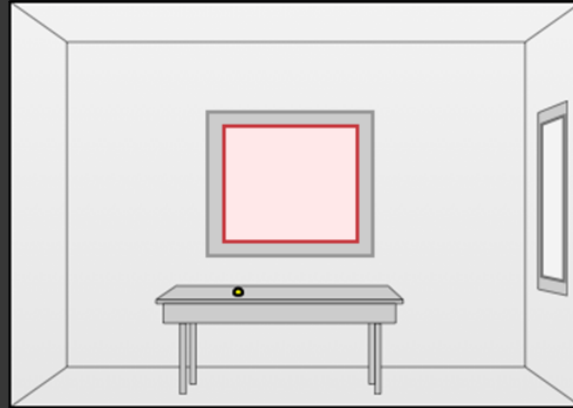
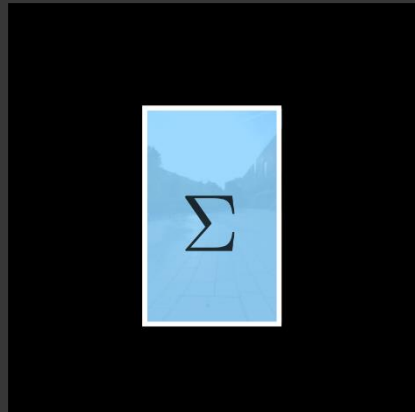

Sampling multiple portals

Scene

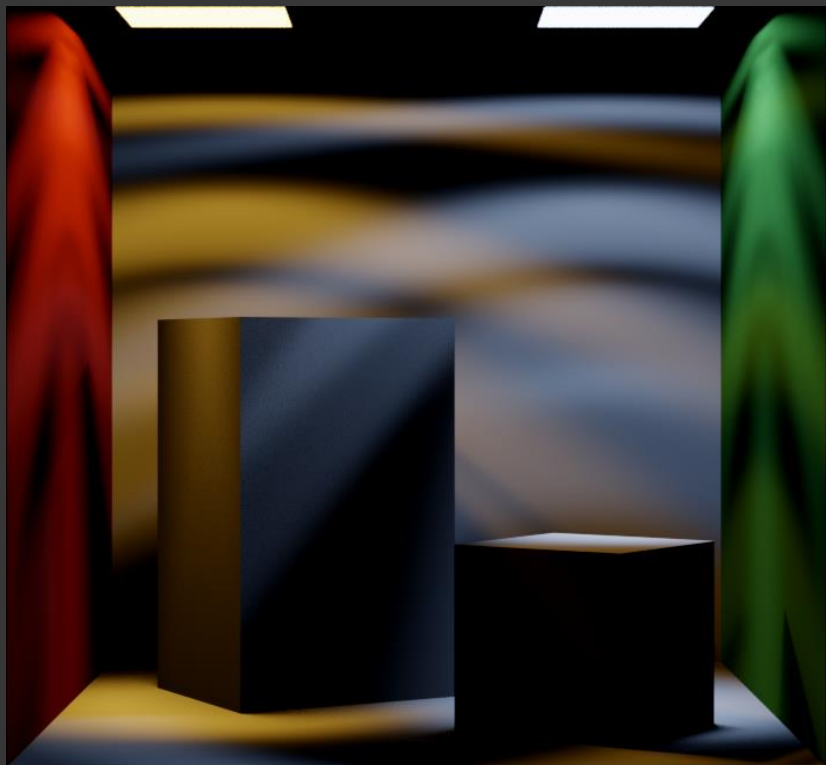

Sample Allocation

